

TS5A3167 0.9-Ω 1-channel 1:1 SPST Analog Switch

1 Features

- Isolation in Powered-Off Mode, $V_{CC} = 0$
- Low ON-State Resistance (0.9 Ω)
- Control Inputs Are 5.5-V Tolerant
- Low Charge Injection
- Low Total Harmonic Distortion (THD)
- 1.65-V to 5.5-V Single-Supply Operation
- Latch-Up Performance Exceeds 100 mA Per JESD 78, Class II
- ESD Performance Tested Per JESD 22
 - 2000-V Human-Body Model (A114-B, Class II)
 - 1000-V Charged-Device Model (C101)

2 Applications

- Cell Phones
- PDAs
- Portable Instrumentation
- Audio and Video Signal Routing
- Low-Voltage Data-Acquisition Systems
- Communication Circuits
- Modems
- Hard Drives
- Computer Peripherals
- Wireless Terminals and Peripherals
- Microphone Switching – Notebook Docking

3 Description

The TS5A3167 is a bidirectional, single-channel, single-pole double-throw (SPDT) analog switch that is designed to operate from 1.65 V to 5.5 V. The TS5A3167 device offers a low ON-state resistance. The device has excellent total harmonic distortion (THD) performance and consumes very low power. These features make this device suitable for portable audio applications.

Device Information⁽¹⁾

| PART NUMBER | PACKAGE | BODY SIZE (NOM) |
|-------------|---------|-------------------|
| TS5A3167 | SOT-23 | 2.90 mm x 1.60 mm |
| | SC70 | 2.00 mm x 1.25 mm |
| | DSBGA | 1.50 mm x 0.90 mm |

(1) For all available packages, see the orderable addendum at the end of the data sheet.

Simple Schematic

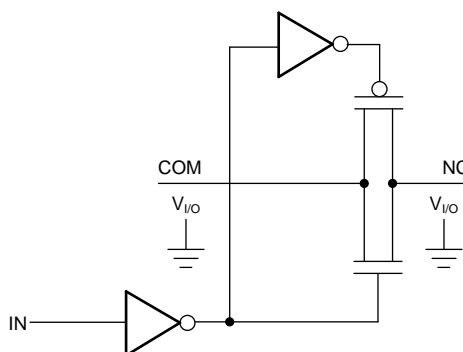

Table of Contents

| | | | |
|---|----------|--|-----------|
| 1 Features | 1 | 7 Parameter Measurement Information | 15 |
| 2 Applications | 1 | 8 Detailed Description | 18 |
| 3 Description | 1 | 8.1 Overview | 18 |
| 4 Revision History | 2 | 8.2 Functional Block Diagram | 18 |
| 5 Pin Configuration and Functions | 3 | 8.3 Feature Description | 18 |
| 6 Specifications | 4 | 8.4 Device Functional Modes | 18 |
| 6.1 Absolute Maximum Ratings | 4 | 9 Application and Implementation | 19 |
| 6.2 ESD Ratings | 4 | 9.1 Application Information | 19 |
| 6.3 Recommended Operating Conditions | 4 | 9.2 Typical Application | 19 |
| 6.4 Thermal Information | 4 | 10 Power Supply Recommendations | 20 |
| 6.5 Electrical Characteristics for 5-V Supply | 5 | 11 Layout | 21 |
| 6.6 Electrical Characteristics for 5-V Supply (continued) | 6 | 11.1 Layout Guidelines | 21 |
| 6.7 Electrical Characteristics for 3.3-V Supply | 7 | 11.2 Layout Example | 21 |
| 6.8 Electrical Characteristics for 3.3-V Supply (continued) | 8 | 12 Device and Documentation Support | 22 |
| 6.9 Electrical Characteristics for 2.5-V Supply | 9 | 12.1 Documentation Support | 22 |
| 6.10 Electrical Characteristics for 2.5-V Supply (continued) | 10 | 12.2 Receiving Notification of Documentation Updates | 22 |
| 6.11 Electrical Characteristics for 1.8-V Supply | 11 | 12.3 Community Resources | 22 |
| 6.12 Electrical Characteristics for 1.8-V Supply (continued) | 12 | 12.4 Trademarks | 23 |
| 6.13 Typical Performance | 13 | 12.5 Electrostatic Discharge Caution | 23 |
| | | 12.6 Glossary | 23 |
| | | 13 Mechanical, Packaging, and Orderable Information | 23 |

4 Revision History

NOTE: Page numbers for previous revisions may differ from page numbers in the current version.

Changes from Revision B (March 2017) to Revision C

Page

- Changed the DSBGA Body Size From: 1.50 mm x 9.00 mm To: 1.50 mm x 0.90 mm in the *Device Information* table 1
- Changed the YZP package pinout view From: Top View To: Bottom View 3

Changes from Revision A (October 2012) to Revision B

Page

- Added the *Device Information* table, *Pin Configuration and Functions*, *ESD Ratings*, *Recommended Operating Conditions*, *Thermal Information*, *Detailed Description*, *Feature Description*, *Device Functional Modes*, *Application and Implementation*, *Power Supply Recommendations*, *Layout*, *Device and Documentation Support*..... 1
- Removed *ORDERING INFORMATION* table 1

Changes from Original (February 2005) to Revision A

Page

- Updated *ORDERING INFORMATION* table..... 1

5 Pin Configuration and Functions

DBV or DCK Package
5-Pin (SOT-23 or SC70)
Top View

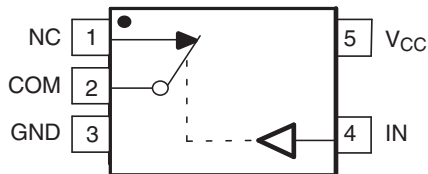

Pin Functions

| PIN NUMBER | NAME | DESCRIPTION |
|------------|-----------------|---|
| 1 | NC | Normally Closed |
| 2 | COM | Common |
| 3 | GND | Ground |
| 4 | IN | Digital control pin, COM connected to NC when logic low |
| 5 | V _{CC} | Power Supply |

YZP Package
5-Pin (DSBGA)
Bottom View

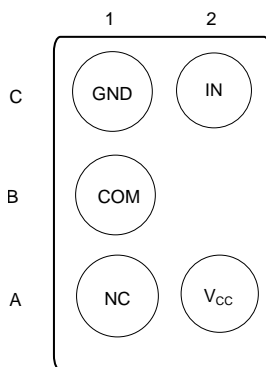

Pin Functions

| PIN NUMBER | NAME | DESCRIPTION |
|------------|-----------------|---|
| A1 | NC | Normally Closed |
| B1 | COM | Common |
| C1 | GND | Ground |
| A2 | V _{CC} | Power Supply |
| C2 | IN | Digital control pin, COM connected to NC when logic low |

6 Specifications

6.1 Absolute Maximum Ratings⁽¹⁾⁽²⁾

over operating free-air temperature range (unless otherwise noted)

| | | MIN | MAX | UNIT |
|-----------------------|--|--|----------------|------|
| V_{CC} | Supply voltage range ⁽³⁾ | -0.5 | 6.5 | V |
| V_{NC} V_{COM} | Analog voltage range ⁽³⁾⁽⁴⁾⁽⁵⁾ | -0.5 | $V_{CC} + 0.5$ | V |
| I_K | Analog port diode current | $V_{NC}, V_{COM} < 0$ | | mA |
| I_{NC} I_{COM} | On-state switch current On-state peak switch current ⁽⁶⁾ | $V_{NC}, V_{COM} = 0 \text{ to } V_{CC}$ | | mA |
| V_I | Digital input voltage range ⁽³⁾⁽⁴⁾ | -0.5 | 6.5 | V |
| I_{IK} | Digital clamp current | $V_I < 0$ | | mA |
| I_{CC} | Continuous current through V_{CC} | | 100 | mA |
| I_{GND} | Continuous current through GND | -100 | | mA |
| T_{stg} | Storage temperature range | -65 | 150 | °C |

- (1) Stresses beyond those listed under "absolute maximum ratings" may cause permanent damage to the device. These are stress ratings only, and functional operation of the device at these or any other conditions beyond those indicated under "recommended operating conditions" is not implied. Exposure to absolute-maximum-rated conditions for extended periods may affect device reliability.
- (2) The algebraic convention, whereby the most negative value is a minimum and the most positive value is a maximum.
- (3) All voltages are with respect to ground, unless otherwise specified.
- (4) The input and output voltage ratings may be exceeded if the input and output clamp-current ratings are observed.
- (5) This value is limited to 5.5 V maximum.
- (6) Pulse at 1-ms duration < 10% duty cycle.

6.2 ESD Ratings

| | | VALUE | UNIT |
|--|---|-------|------|
| $V_{(ESD)}$ | Electrostatic discharge | | |
| | Human-body model (HBM), per ANSI/ESDA/JEDEC JS-001 ⁽¹⁾ | ±2000 | V |
| Charged-device model (CDM), per JEDEC specification JESD22-C101 ⁽²⁾ | ±1000 | | |

- (1) JEDEC document JEP155 states that 500-V HBM allows safe manufacturing with a standard ESD control process.
- (2) JEDEC document JEP157 states that 250-V CDM allows safe manufacturing with a standard ESD control process.

6.3 Recommended Operating Conditions

over operating free-air temperature range (unless otherwise noted)

| | | MIN | MAX | UNIT |
|-----------------------|-----------------------------|------|----------|------|
| V_{CC} | Supply voltage range | 1.65 | 5.5 | V |
| V_{NC} V_{COM} | Analog voltage range | 0 | V_{CC} | V |
| V_I | Digital input voltage range | 0 | V_{CC} | V |

6.4 Thermal Information

| THERMAL METRIC ⁽¹⁾ | TS5A3167 | | | UNIT | |
|-------------------------------|--|--------------|-------------|-------|------|
| | DBV (SOT-23) | DCK (SOT-23) | YZP (DSBGA) | | |
| | 5 PINS | 5 PINS | 5 PINS | | |
| $R_{\theta JA}$ | Junction-to-ambient thermal resistance | 230.3 | 268.0 | 146.2 | °C/W |
| $R_{\theta JC(top)}$ | Junction-to-case (top) thermal resistance | 111.9 | 171.8 | 1.4 | °C/W |
| $R_{\theta JB}$ | Junction-to-board thermal resistance | 69.5 | 64.5 | 39.3 | °C/W |
| Ψ_{JT} | Junction-to-top characterization parameter | 33.0 | 40.5 | 0.7 | °C/W |
| Ψ_{JB} | Junction-to-board characterization parameter | 69.0 | 62.9 | 39.8 | °C/W |
| $R_{\theta JC(bot)}$ | Junction-to-case (bottom) thermal resistance | n/a | n/a | n/a | °C/W |

- (1) For more information about traditional and new thermal metrics, see the [Semiconductor and IC Package Thermal Metrics](#) application report.

6.5 Electrical Characteristics for 5-V Supply⁽¹⁾

 $V_{CC} = 4.5\text{ V to }5.5\text{ V}$, $T_A = -40^\circ\text{C to }85^\circ\text{C}$ (unless otherwise noted)

| PARAMETER | SYMBOL | TEST CONDITIONS | T_A | V_{CC} | MIN | TYP | MAX | UNIT | |
|------------------------------------|--------------------------------|---|--|----------------------|-------|-----------------------------|-------------------------------|----------|---------------|
| Analog Switch | | | | | | | | | |
| Peak ON resistance | r_{peak} | $0 \leq V_{\text{NC}} \leq V_{\text{CC}}$, $I_{\text{COM}} = -100\text{ mA}$, | Switch ON, See Figure 13 | 25°C Full | 4.5 V | 0.8 1.1 1.2 | | Ω | |
| ON-state resistance | r_{on} | $V_{\text{NC}} = 2.5\text{ V}$, $I_{\text{COM}} = -100\text{ mA}$, | Switch ON, See Figure 13 | 25°C Full | 4.5 V | 0.75 0.9 1 | | Ω | |
| ON-state resistance flatness | $r_{\text{on(flat)}}$ | $0 \leq V_{\text{NC}} \leq V_{\text{CC}}$, $I_{\text{COM}} = -100\text{ mA}$, $V_{\text{NC}} = 1\text{ V}, 1.5\text{ V}, 2.5\text{ V}$, $I_{\text{COM}} = -100\text{ mA}$, | Switch ON, See Figure 13 | 25°C 25°C Full | 4.5 V | 0.2 0.15 0.25 0.25 | | Ω | |
| NC OFF leakage current | $I_{\text{NC(OFF)}}$ | $V_{\text{NC}} = 1\text{ V}$, $V_{\text{COM}} = 4.5\text{ V}$, or $V_{\text{NC}} = 4.5\text{ V}$, $V_{\text{COM}} = 1\text{ V}$, | Switch OFF, See Figure 14 | 25°C Full | 5.5 V | 0 4 20 -150 150 | | nA | |
| | $I_{\text{NC(PWROFF)}}$ | $V_{\text{NC}} = 0\text{ to }5.5\text{ V}$, $V_{\text{COM}} = 5.5\text{ V to }0$, | | 25°C Full | | 0 V | -10 0.2 10 -50 50 | | μA |
| COM OFF leakage current | $I_{\text{COM(OFF)}}$ | $V_{\text{COM}} = 1\text{ V}$, $V_{\text{NC}} = 4.5\text{ V}$, or $V_{\text{COM}} = 4.5\text{ V}$, $V_{\text{NC}} = 1\text{ V}$, | Switch OFF, See Figure 14 | 25°C Full | 5.5 V | 0 4 20 -150 150 | | nA | |
| | $I_{\text{COM(PWROFF)}}$ | $V_{\text{COM}} = 5.5\text{ V to }0$, $V_{\text{NC}} = 0\text{ to }5.5\text{ V}$, | | 25°C Full | | 0 V | -10 0.2 10 -50 50 | | μA |
| NC ON leakage current | $I_{\text{NC(ON)}}$ | $V_{\text{NC}} = 1\text{ V}$, $V_{\text{COM}} = \text{Open}$, or $V_{\text{NC}} = 4.5\text{ V}$, $V_{\text{COM}} = \text{Open}$, | Switch ON, See Figure 15 | 25°C Full | 5.5 V | -5 0.4 5 -50 50 | | nA | |
| COM ON leakage current | $I_{\text{COM(ON)}}$ | $V_{\text{COM}} = 1\text{ V}$, $V_{\text{NC}} = \text{Open}$, or $V_{\text{COM}} = 4.5\text{ V}$, $V_{\text{NC}} = \text{Open}$, | Switch ON, See Figure 15 | 25°C Full | | 5.5 V | -5 0.4 5 -20 20 | | nA |
| Digital Control Inputs (IN) | | | | | | | | | |
| Input logic high | V_{IH} | | | Full | | 2.4 | 5.5 | V | |
| Input logic low | V_{IL} | | | Full | | 0 | 0.8 | V | |
| Input leakage current | $I_{\text{IH}}, I_{\text{IL}}$ | $V_{\text{I}} = 5.5\text{ V or }0$ | | 25°C | 5.5 V | -2 | 0.3 | 2 | nA |
| | | | | Full | | -20 | 20 | | |

(1) The algebraic convention, whereby the most negative value is a minimum and the most positive value is a maximum.

6.6 Electrical Characteristics for 5-V Supply⁽¹⁾ (continued)

V_{CC} = 4.5 V to 5.5 V, T_A = –40°C to 85°C (unless otherwise noted)

| PARAMETER | SYMBOL | TEST CONDITIONS | T _A | V _{CC} | MIN | TYP | MAX | UNIT |
|---------------------------|-----------------------|--|----------------|-----------------|------|--------|-----|------|
| Dynamic | | | | | | | | |
| Turn-on time | t _{ON} | V _{COM} = V _{CC} , R _L = 50 Ω, C _L = 35 pF, See Figure 17 | 25°C | 5 V | 1 | 4.5 | 7.5 | ns |
| | | | Full | 4.5 V to 5.5 V | 1 | | 9 | |
| Turn-off time | t _{OFF} | V _{COM} = V _{CC} , R _L = 50 Ω, C _L = 35 pF, See Figure 17 | 25°C | 5 V | 4.5 | 8 | 11 | ns |
| | | | Full | 4.5 V to 5.5 V | 3.5 | | 13 | |
| Charge injection | Q _C | V _{GEN} = 0, R _{GEN} = 0 , C _L = 1 nF, See Figure 20 | 25°C | 5 V | | 6 | | pC |
| NC OFF capacitance | C _{NC(OFF)} | V _{NC} = V _{CC} or GND, Switch OFF, See Figure 16 | 25°C | 5 V | | 19 | | pF |
| COM OFF capacitance | C _{COM(OFF)} | V _{COM} = V _{CC} or GND, Switch OFF, See Figure 16 | 25°C | 5 V | | 18 | | pF |
| NC ON capacitance | C _{NC(ON)} | V _{NC} = V _{CC} or GND, Switch ON, See Figure 16 | 25°C | 5 V | | 35.5 | | pF |
| COM ON capacitance | C _{COM(ON)} | V _{COM} = V _{CC} or GND, Switch ON, See Figure 16 | 25°C | 5 V | | 35.5 | | pF |
| Digital input capacitance | C _I | V _I = V _{CC} or GND, See Figure 16 | 25°C | 5 V | | 2 | | pF |
| Bandwidth | BW | R _L = 50 Ω, Switch ON, See Figure 18 | 25°C | 5 V | | 150 | | MHz |
| OFF isolation | O _{ISO} | R _L = 50 Ω, f = 1 MHz, Switch OFF, See Figure 19 | 25°C | 5 V | | –62 | | dB |
| Total harmonic distortion | THD | R _L = 600 Ω, C _L = 50 pF, f = 20 Hz to 20 kHz, See Figure 21 | 25°C | 5 V | | 0.005% | | |
| Supply | | | | | | | | |
| Positive supply current | I _{CC} | V _I = V _{CC} or GND, Switch ON or OFF | 25°C | 5.5 V | 0.01 | | 0.1 | μA |
| | | | Full | | | | 1 | |

(1) The algebraic convention, whereby the most negative value is a minimum and the most positive value is a maximum.

6.7 Electrical Characteristics for 3.3-V Supply⁽¹⁾

 $V_{CC} = 3\text{ V to }3.6\text{ V}$, $T_A = -40^\circ\text{C to }85^\circ\text{C}$ (unless otherwise noted)

| PARAMETER | SYMBOL | TEST CONDITIONS | T_A | V_{CC} | MIN | TYP | MAX | UNIT | |
|------------------------------------|-------------------|--|--|----------|-------|------|------|----------|---------------|
| Analog Switch | | | | | | | | | |
| Peak ON resistance | r_{peak} | $0 \leq V_{NC} \leq V_{CC}$, $I_{COM} = -100\text{ mA}$, | Switch ON, See Figure 13 | 25°C | 3 V | 1.3 | 1.6 | Ω | |
| | | | | Full | | 1.8 | | | |
| ON-state resistance | r_{on} | $V_{NC} = 2\text{ V}$, $I_{COM} = -100\text{ mA}$, | Switch ON, See Figure 13 | 25°C | 3 V | 1.1 | 1.5 | Ω | |
| | | | | Full | | 1.7 | | | |
| ON-state resistance flatness | $r_{on(flat)}$ | $0 \leq V_{NC} \leq V_{CC}$, $I_{COM} = -100\text{ mA}$, | Switch ON, See Figure 13 | 25°C | 3 V | 0.3 | | Ω | |
| | | | | 25°C | | 0.15 | 0.25 | | |
| | | Full | 0.25 | | | | | | |
| NC OFF leakage current | $I_{NC(OFF)}$ | $V_{NC} = 1\text{ V}$, $V_{COM} = 3\text{ V}$, or $V_{NC} = 3\text{ V}$, $V_{COM} = 1\text{ V}$, | Switch OFF, See Figure 14 | 25°C | 3.6 V | -5 | 0.5 | 5 | nA |
| | | | | Full | | -50 | 50 | | |
| | $I_{NC(PWROFF)}$ | $V_{NC} = 0\text{ to }3.6\text{ V}$, $V_{COM} = 3.6\text{ V to }0$, | | 25°C | 0 V | -5 | 0.1 | 5 | μA |
| | | | | Full | | -25 | 25 | | |
| COM OFF leakage current | $I_{COM(OFF)}$ | $V_{COM} = 1\text{ V}$, $V_{NC} = 3\text{ V}$, or $V_{COM} = 3\text{ V}$, $V_{NC} = 1\text{ V}$, | Switch OFF, See Figure 14 | 25°C | 3.6 V | -5 | 0.5 | 5 | nA |
| | | | | Full | | -50 | 50 | | |
| | $I_{COM(PWROFF)}$ | $V_{COM} = 3.6\text{ V to }0$, $V_{NC} = 0\text{ to }3.6\text{ V}$, | | 25°C | 0 V | -5 | 0.1 | 5 | μA |
| | | | | Full | | -25 | 25 | | |
| NC ON leakage current | $I_{NC(ON)}$ | $V_{NC} = 1\text{ V}$, $V_{COM} = \text{Open}$, or $V_{NC} = 3\text{ V}$, $V_{COM} = \text{Open}$, | Switch ON, See Figure 15 | 25°C | 3.6 V | -2 | 0.3 | 2 | nA |
| | | | | Full | | -20 | 20 | | |
| COM ON leakage current | $I_{COM(ON)}$ | $V_{COM} = 1\text{ V}$, $V_{NC} = \text{Open}$, or $V_{COM} = 3\text{ V}$, $V_{NC} = \text{Open}$, | Switch ON, See Figure 15 | 25°C | 3.6 V | -2 | 0.3 | 2 | nA |
| | | | | Full | | -20 | 20 | | |
| Digital Control Inputs (IN) | | | | | | | | | |
| Input logic high | V_{IH} | | | Full | | 2 | 5.5 | V | |
| Input logic low | V_{IL} | | | Full | | 0 | 0.8 | V | |
| Input leakage current | I_{IH}, I_{IL} | $V_I = 5.5\text{ V or }0$ | | 25°C | 3.6 V | -2 | 0.3 | 2 | nA |
| | | | | Full | | -20 | 20 | | |

(1) The algebraic convention, whereby the most negative value is a minimum and the most positive value is a maximum.

6.8 Electrical Characteristics for 3.3-V Supply⁽¹⁾ (continued)

$V_{CC} = 3\text{ V to }3.6\text{ V}$, $T_A = -40^\circ\text{C to }85^\circ\text{C}$ (unless otherwise noted)

| PARAMETER | SYMBOL | TEST CONDITIONS | T_A | VCC | MIN | TYP | MAX | UNIT | |
|------------------------------|----------------|---|--|------|-----------------|-------|-------|---------------|----|
| Dynamic | | | | | | | | | |
| Turn-on time | t_{ON} | $V_{COM} = V_{CC}$, $R_L = 50\ \Omega$, | $C_L = 35\text{ pF}$, See Figure 17 | 25°C | 3.3 V | 1.5 | 5 | 9.5 | ns |
| | | | | Full | 3 V to 3.6 V | 1.0 | | 10 | |
| Turn-off time | t_{OFF} | $V_{COM} = V_{CC}$, $R_L = 50\ \Omega$, | $C_L = 35\text{ pF}$, See Figure 17 | 25°C | 3.3 V | 4.5 | 8.5 | 11 | ns |
| | | | | Full | 3 V to 3.6 V | 3 | | 12.5 | |
| Charge injection | Q_C | $V_{GEN} = 0$, $R_{GEN} = 0$, | $C_L = 1\text{ nF}$, See Figure 20 | 25°C | 3.3 V | | 6 | pC | |
| NC OFF capacitance | $C_{NC(OFF)}$ | $V_{NC} = V_{CC}$ or GND, | Switch OFF, See Figure 16 | 25°C | 3.3 V | | 19.5 | pF | |
| COM OFF capacitance | $C_{COM(OFF)}$ | $V_{COM} = V_{CC}$ or GND, | Switch OFF, See Figure 16 | 25°C | 3.3 V | | 18.5 | pF | |
| NC ON capacitance | $C_{NC(ON)}$ | $V_{NC} = V_{CC}$ or GND, | Switch ON, See Figure 16 | 25°C | 3.3 V | | 36 | pF | |
| COM ON capacitance | $C_{COM(ON)}$ | $V_{COM} = V_{CC}$ or GND, | Switch ON, See Figure 16 | 25°C | 3.3 V | | 36 | pF | |
| Digital input capacitance | C_I | $V_I = V_{CC}$ or GND, | See Figure 16 | 25°C | 3.3 V | | 2 | pF | |
| Bandwidth | BW | $R_L = 50\ \Omega$, | Switch ON, See Figure 18 | 25°C | 3.3 V | | 150 | MHz | |
| OFF isolation | O_{ISO} | $R_L = 50\ \Omega$, $f = 1\text{ MHz}$, | Switch OFF, See Figure 19 | 25°C | 3.3 V | | -62 | dB | |
| Total harmonic distortion | THD | $R_L = 600\ \Omega$, $C_L = 50\text{ pF}$, | $f = 20\text{ Hz to }20\text{ kHz}$, See Figure 21 | 25°C | 3.3 V | | 0.01% | | |
| Supply | | | | | | | | | |
| Positive supply current | I_{CC} | $V_I = V_{CC}$ or GND, | Switch ON or OFF | 25°C | 3.6 V | 0.001 | 0.05 | μA | |
| | | | | Full | | | 0.3 | | |

(1) The algebraic convention, whereby the most negative value is a minimum and the most positive value is a maximum.

6.9 Electrical Characteristics for 2.5-V Supply⁽¹⁾

 $V_{CC} = 2.3 \text{ V to } 2.7 \text{ V}$, $T_A = -40^\circ\text{C to } 85^\circ\text{C}$ (unless otherwise noted)

| PARAMETER | SYMBOL | TEST CONDITIONS | T_A | V_{CC} | MIN | TYP | MAX | UNIT | |
|------------------------------------|-------------------|--|--|----------|-------|-----|------|----------|---------------|
| Analog Switch | | | | | | | | | |
| Peak ON resistance | r_{peak} | $0 \leq V_{NC} \leq V_{CC}$, $I_{COM} = -100 \text{ mA}$, | Switch ON, See Figure 13 | 25°C | 2.3 V | 1.8 | 2.4 | Ω | |
| | | | | Full | | 2.6 | | | |
| ON-state resistance | r_{on} | $V_{NC} = 2 \text{ V}$, $I_{COM} = -100 \text{ mA}$, | Switch ON, See Figure 13 | 25°C | 2.3 V | 1.2 | 2.1 | Ω | |
| | | | | Full | | 2.4 | | | |
| ON-state resistance flatness | $r_{on(Flat)}$ | $0 \leq V_{NC} \leq V_{CC}$, $I_{COM} = -100 \text{ mA}$, | Switch ON, See Figure 13 | 25°C | 2.3 V | 0.7 | | Ω | |
| | | | | 25°C | | 0.4 | 0.6 | | |
| | | Full | 0.6 | | | | | | |
| NC OFF leakage current | $I_{NC(OFF)}$ | $V_{NC} = 1 \text{ V}$, $V_{COM} = 3 \text{ V}$, or $V_{NC} = 3 \text{ V}$, $V_{COM} = 1 \text{ V}$, | Switch OFF, See Figure 14 | 25°C | 2.7 V | -5 | 0.3 | 5 | nA |
| | | | | Full | | -50 | | 50 | |
| | $I_{NC(PWROFF)}$ | $V_{NC} = 0 \text{ to } 3.6 \text{ V}$, $V_{COM} = 3.6 \text{ V to } 0$, | | 25°C | 0 V | -2 | 0.05 | 2 | μA |
| | | | | Full | | -15 | | 15 | |
| COM OFF leakage current | $I_{COM(OFF)}$ | $V_{COM} = 1 \text{ V}$, $V_{NC} = 3 \text{ V}$, or $V_{COM} = 3 \text{ V}$, $V_{NC} = 1 \text{ V}$, | Switch OFF, See Figure 14 | 25°C | 2.7 V | -5 | 0.3 | 5 | nA |
| | | | | Full | | -50 | | 50 | |
| | $I_{COM(PWROFF)}$ | $V_{COM} = 3.6 \text{ V to } 0$, $V_{NC} = 0 \text{ to } 3.6 \text{ V}$, | | 25°C | 0 V | -2 | 0.05 | 2 | μA |
| | | | | Full | | -15 | | 15 | |
| NC ON leakage current | $I_{NC(ON)}$ | $V_{NC} = 1 \text{ V}$, $V_{COM} = \text{Open}$, or $V_{NC} = 3 \text{ V}$, $V_{COM} = \text{Open}$, | Switch ON, See Figure 15 | 25°C | 2.7 V | -2 | 0.3 | 2 | nA |
| | | | | Full | | -20 | | 20 | |
| COM ON leakage current | $I_{COM(ON)}$ | $V_{COM} = 1 \text{ V}$, $V_{NC} = \text{Open}$, or $V_{COM} = 3 \text{ V}$, $V_{NC} = \text{Open}$, | Switch ON, See Figure 15 | 25°C | 2.7 V | -2 | 0.3 | 2 | nA |
| | | | | Full | | -20 | | 20 | |
| Digital Control Inputs (IN) | | | | | | | | | |
| Input logic high | V_{IH} | | | Full | | 1.8 | 5.5 | V | |
| Input logic low | V_{IL} | | | Full | | 0 | 0.6 | V | |
| Input leakage current | I_{IH}, I_{IL} | $V_I = 5.5 \text{ V or } 0$ | | 25°C | 2.7 V | -2 | 0.3 | 2 | nA |
| | | | | Full | | -20 | | 20 | |

(1) The algebraic convention, whereby the most negative value is a minimum and the most positive value is a maximum.

6.10 Electrical Characteristics for 2.5-V Supply⁽¹⁾ (continued)

$V_{CC} = 2.3 \text{ V to } 2.7 \text{ V}$, $T_A = -40^\circ\text{C to } 85^\circ\text{C}$ (unless otherwise noted)

| PARAMETER | SYMBOL | TEST CONDITIONS | T_A | VCC | MIN | TYP | MAX | UNIT | |
|------------------------------|----------------|---|---|------|-------------------|-------|-------|---------------|----|
| Dynamic | | | | | | | | | |
| Turn-on time | t_{ON} | $V_{COM} = V_{CC}$, $R_L = 50 \Omega$, | $C_L = 35 \text{ pF}$, See Figure 17 | 25°C | 2.5 V | 2 | 6 | 10 | ns |
| | | | | Full | 2.3 V to 2.7 V | 1 | | 12 | |
| Turn-off time | t_{OFF} | $V_{COM} = V_{CC}$, $R_L = 50 \Omega$, | $C_L = 35 \text{ pF}$, See Figure 17 | 25°C | 2.5 V | 4.5 | 8 | 10.5 | ns |
| | | | | Full | 2.3 V to 2.7 V | 3 | | 15 | |
| Charge injection | Q_C | $V_{GEN} = 0$, $R_{GEN} = 0$, | $C_L = 1 \text{ nF}$, See Figure 20 | 25°C | 2.5 V | | 4 | pC | |
| NC OFF capacitance | $C_{NC(OFF)}$ | $V_{NC} = V_{CC}$ or GND, | Switch OFF, See Figure 16 | 25°C | 2.5 V | | 19.5 | pF | |
| COM OFF capacitance | $C_{COM(OFF)}$ | $V_{COM} = V_{CC}$ or GND, | Switch OFF, See Figure 16 | 25°C | 2.5 V | | 18.5 | pF | |
| NC ON capacitance | $C_{NC(ON)}$ | $V_{NC} = V_{CC}$ or GND, | Switch ON, See Figure 16 | 25°C | 2.5 V | | 36.5 | pF | |
| COM ON capacitance | $C_{COM(ON)}$ | $V_{COM} = V_{CC}$ or GND, | Switch ON, See Figure 16 | 25°C | 2.5 V | | 36.5 | pF | |
| Digital input capacitance | C_I | $V_I = V_{CC}$ or GND, | See Figure 16 | 25°C | 2.5 V | | 2 | pF | |
| Bandwidth | BW | $R_L = 50 \Omega$, | Switch ON, See Figure 18 | 25°C | 2.5 V | | 150 | MHz | |
| OFF isolation | O_{ISO} | $R_L = 50 \Omega$, $f = 1 \text{ MHz}$, | Switch OFF, See Figure 19 | 25°C | 2.5 V | | -62 | dB | |
| Total harmonic distortion | THD | $R_L = 600 \Omega$, $C_L = 50 \text{ pF}$, | $f = 20 \text{ Hz to } 20 \text{ kHz}$, See Figure 21 | 25°C | 2.5 V | | 0.02% | | |
| Supply | | | | | | | | | |
| Positive supply current | I_{CC} | $V_I = V_{CC}$ or GND, | Switch ON or OFF | 25°C | 2.7 V | 0.001 | 0.02 | μA | |
| | | | | Full | | | 0.25 | | |

(1) The algebraic convention, whereby the most negative value is a minimum and the most positive value is a maximum.

6.11 Electrical Characteristics for 1.8-V Supply⁽¹⁾

 $V_{CC} = 1.65\text{ V to }1.95\text{ V}$, $T_A = -40^\circ\text{C to }85^\circ\text{C}$ (unless otherwise noted)

| PARAMETER | SYMBOL | TEST CONDITIONS | T_A | V_{CC} | MIN | TYP | MAX | UNIT |
|------------------------------------|-------------------|--|--|----------|--------|-----|-----|---------------|
| Analog Switch | | | | | | | | |
| Peak ON resistance | r_{peak} | $0 \leq V_{NC} \leq V_{CC}$, $I_{COM} = -100\text{ mA}$, | Switch ON, See Figure 13 | 25°C | 1.65 V | 4.2 | 25 | Ω |
| | | | | Full | | 30 | | |
| ON-state resistance | r_{on} | $V_{NC} = 2\text{ V}$, $I_{COM} = -100\text{ mA}$, | Switch ON, See Figure 13 | 25°C | 1.65 V | 1.6 | 3.9 | Ω |
| | | | | Full | | 4.0 | | |
| ON-state resistance flatness | $r_{on(flat)}$ | $0 \leq V_{NC} \leq V_{CC}$, $I_{COM} = -100\text{ mA}$, | Switch ON, See Figure 13 | 25°C | 1.65 V | 2.8 | | Ω |
| | | | | 25°C | | 4.1 | 22 | |
| | | Full | 27 | | | | | |
| NC OFF leakage current | $I_{NC(OFF)}$ | $V_{NC} = 1\text{ V}$, $V_{COM} = 3\text{ V}$, or $V_{NC} = 3\text{ V}$, $V_{COM} = 1\text{ V}$, | Switch OFF, See Figure 14 | 25°C | 1.95 V | -5 | 5 | nA |
| | | | | Full | | -50 | 50 | |
| | $I_{NC(PWROFF)}$ | $V_{NC} = 0\text{ to }3.6\text{ V}$, $V_{COM} = 3.6\text{ V to }0$, | | 25°C | 0 V | -2 | 2 | μA |
| | | | | Full | | -10 | 10 | |
| COM OFF leakage current | $I_{COM(OFF)}$ | $V_{COM} = 1\text{ V}$, $V_{NC} = 3\text{ V}$, or $V_{COM} = 3\text{ V}$, $V_{NC} = 1\text{ V}$, | Switch OFF, See Figure 14 | 25°C | 1.95 V | -5 | 5 | nA |
| | | | | Full | | -50 | 50 | |
| | $I_{COM(PWROFF)}$ | $V_{COM} = 0\text{ to }3.6\text{ V}$, $V_{NC} = 3.6\text{ V to }0$, | | 25°C | 0 V | -2 | 2 | μA |
| | | | | Full | | -10 | 10 | |
| NC ON leakage current | $I_{NC(ON)}$ | $V_{NC} = 1\text{ V}$, $V_{COM} = \text{Open}$, or $V_{NC} = 3\text{ V}$, $V_{COM} = \text{Open}$, | Switch ON, See Figure 15 | 25°C | 1.95 V | -2 | 2 | nA |
| | | | | Full | | -20 | 20 | |
| COM ON leakage current | $I_{COM(ON)}$ | $V_{COM} = 1\text{ V}$, $V_{NC} = \text{Open}$, or $V_{COM} = 3\text{ V}$, $V_{NC} = \text{Open}$, | Switch ON, See Figure 15 | 25°C | 1.95 V | -2 | 2 | nA |
| | | | | Full | | -20 | 20 | |
| Digital Control Inputs (IN) | | | | | | | | |
| Input logic high | V_{IH} | | | Full | | 1.5 | 5.5 | V |
| Input logic low | V_{IL} | | | Full | | 0 | 0.6 | V |
| Input leakage current | I_{IH}, I_{IL} | $V_I = 5.5\text{ V or }0$ | | 25°C | 1.95 V | -2 | 0.3 | 2 |
| | | | | Full | | -20 | 20 | nA |

(1) The algebraic convention, whereby the most negative value is a minimum and the most positive value is a maximum.

6.12 Electrical Characteristics for 1.8-V Supply⁽¹⁾ (continued)

$V_{CC} = 1.65\text{ V to }1.95\text{ V}$, $T_A = -40^\circ\text{C to }85^\circ\text{C}$ (unless otherwise noted)

| PARAMETER | SYMBOL | TEST CONDITIONS | T_A | V_{CC} | MIN | TYP | MAX | UNIT | |
|------------------------------|----------------|---|--|----------|---------------------|-------|--------|---------------|----|
| Dynamic | | | | | | | | | |
| Turn-on time | t_{ON} | $V_{COM} = V_{CC}$, $R_L = 50\ \Omega$, | $C_L = 35\text{ pF}$, See Figure 17 | 25°C | 1.8 V | 3 | 9 | 18 | ns |
| | | | | Full | 1.65 V to 1.95 V | 1 | | 20 | |
| Turn-off time | t_{OFF} | $V_{COM} = V_{CC}$, $R_L = 50\ \Omega$, | $C_L = 35\text{ pF}$, See Figure 17 | 25°C | 1.8 V | 5 | 10 | 15.5 | ns |
| | | | | Full | 1.65 V to 1.95 V | 4 | | 18.5 | |
| Charge injection | Q_C | $V_{GEN} = 0$, $R_{GEN} = 0$, | $C_L = 1\text{ nF}$, See Figure 20 | 25°C | 1.8 V | | 2 | pC | |
| NC OFF capacitance | $C_{NC(OFF)}$ | $V_{NC} = V_{CC}$ or GND, | Switch OFF, See Figure 16 | 25°C | 1.8 V | | 19.5 | pF | |
| COM OFF capacitance | $C_{COM(OFF)}$ | $V_{COM} = V_{CC}$ or GND, | Switch OFF, See Figure 16 | 25°C | 1.8 V | | 18.5 | pF | |
| NC ON capacitance | $C_{NC(ON)}$ | $V_{NC} = V_{CC}$ or GND, | Switch ON, See Figure 16 | 25°C | 1.8 V | | 36.5 | pF | |
| COM ON capacitance | $C_{COM(ON)}$ | $V_{COM} = V_{CC}$ or GND, | Switch ON, See Figure 16 | 25°C | 1.8 V | | 36.5 | pF | |
| Digital input capacitance | C_I | $V_I = V_{CC}$ or GND, | See Figure 16 | 25°C | 1.8 V | | 2 | pF | |
| Bandwidth | BW | $R_L = 50\ \Omega$, | Switch ON, See Figure 18 | 25°C | 1.8 V | | 150 | MHz | |
| OFF isolation | O_{ISO} | $R_L = 50\ \Omega$, $f = 1\text{ MHz}$, | Switch OFF, See Figure 19 | 25°C | 1.8 V | | -62 | dB | |
| Total harmonic distortion | THD | $R_L = 600\ \Omega$, $C_L = 50\text{ pF}$, | $f = 20\text{ Hz to }20\text{ kHz}$ See Figure 21 | 25°C | 1.8 V | | 0.055% | | |
| Supply | | | | | | | | | |
| Positive supply current | I_{CC} | $V_I = V_{CC}$ or GND, | Switch ON or OFF | 25°C | 1.95 V | 0.001 | 0.01 | μA | |
| | | | | Full | | | 0.15 | | |

(1) The algebraic convention, whereby the most negative value is a minimum and the most positive value is a maximum.

6.13 Typical Performance

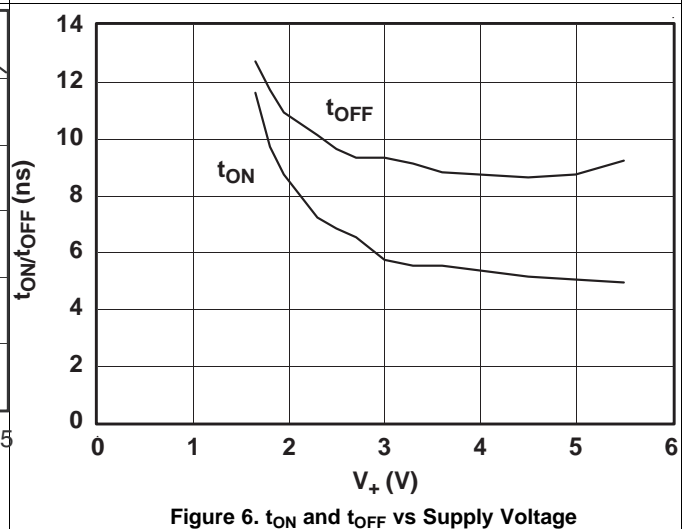
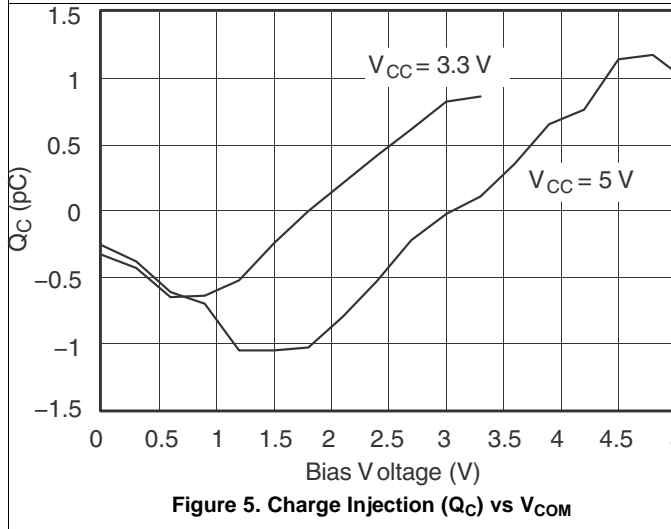
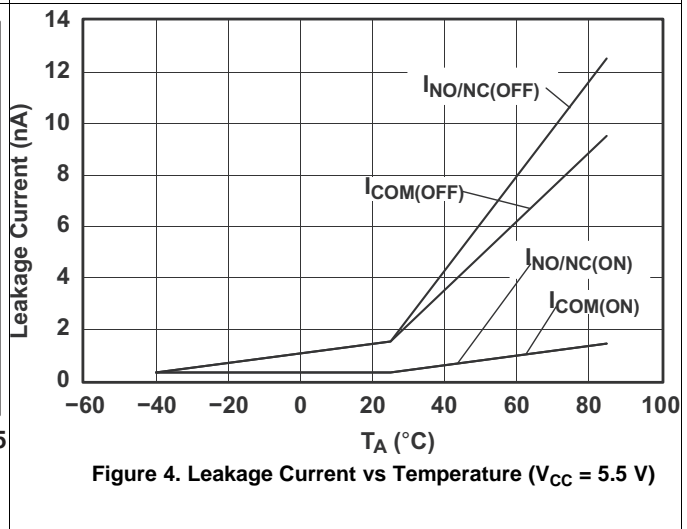
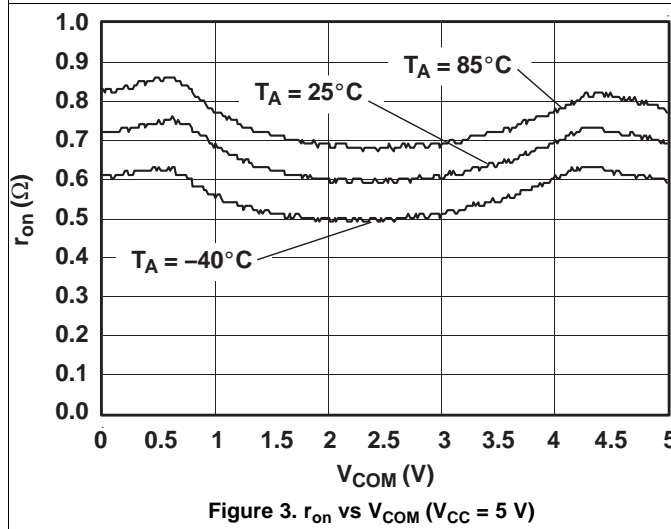
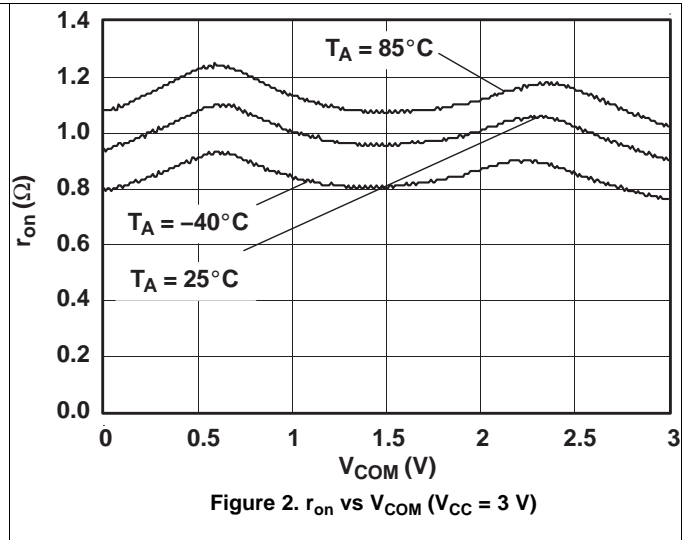
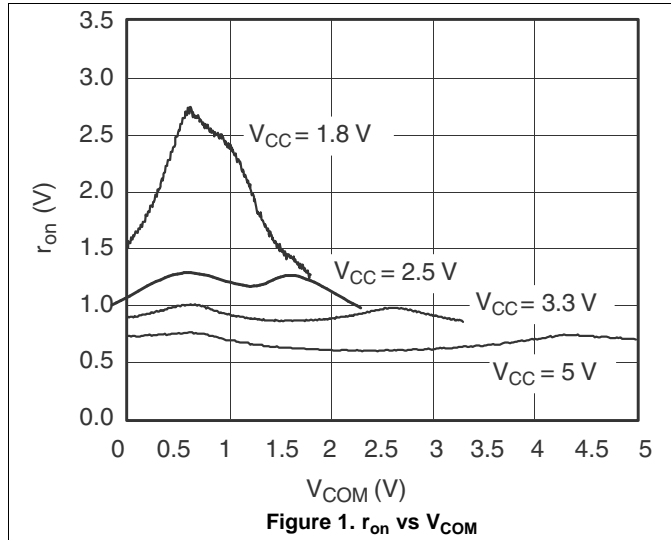

Typical Performance (continued)

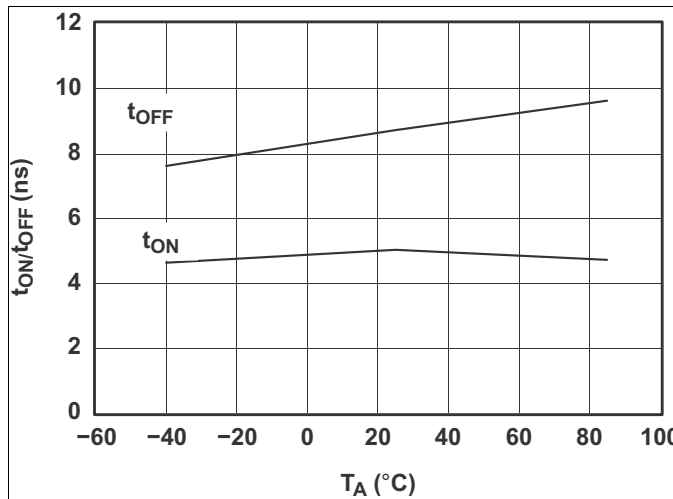

Figure 7. t_{ON} and t_{OFF} vs Temperature ($V_{CC} = 5\text{ V}$)

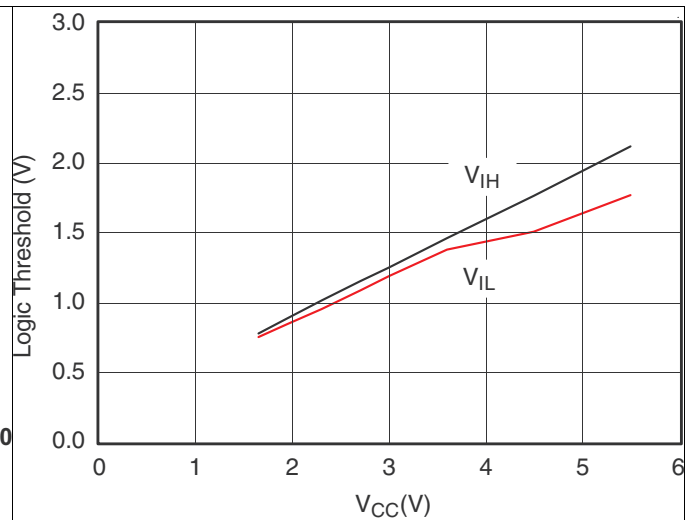

Figure 8. Logic Threshold vs V_{CC}

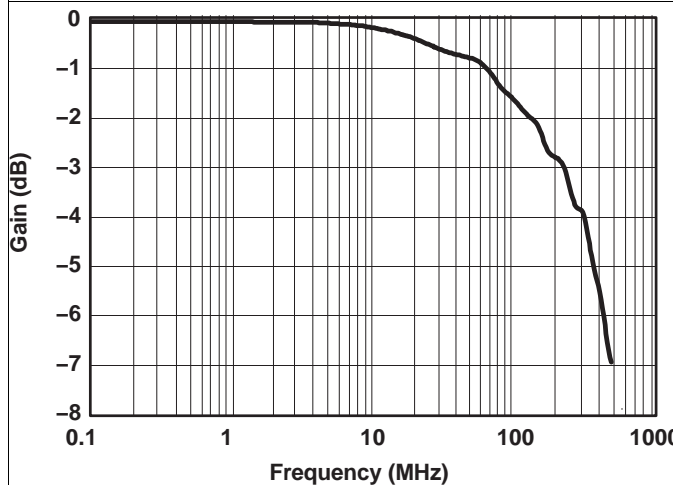

Figure 9. Gain vs Frequency ($V_{CC} = 5\text{ V}$)

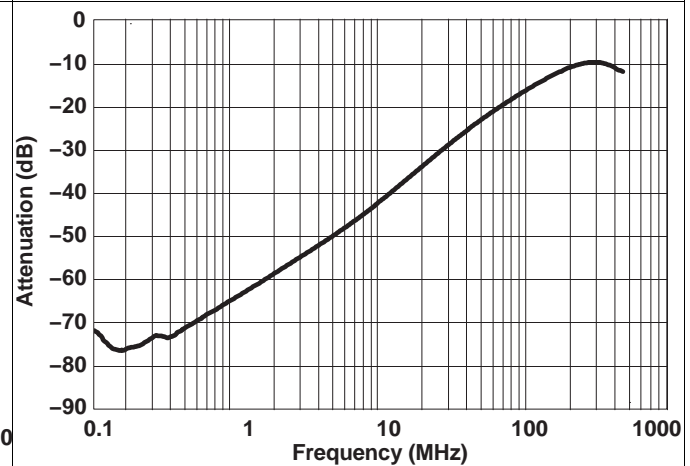

Figure 10. OFF Isolation vs Frequency ($V_{CC} = 5\text{ V}$)

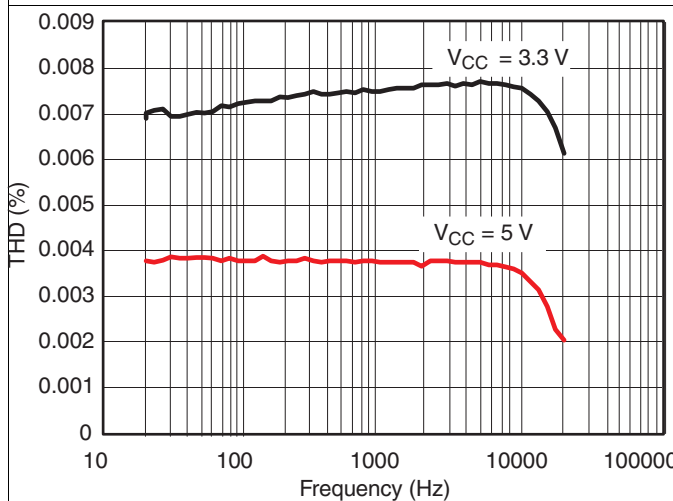

Figure 11. Total Harmonic Distortion vs Frequency ($V_{CC} = 5\text{ V}$)

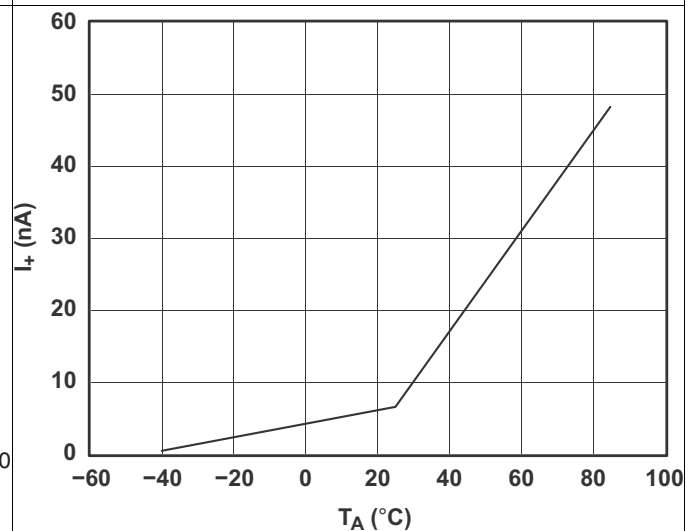

Figure 12. Power-Supply Current vs Temperature ($V_{CC} = 5\text{ V}$)

7 Parameter Measurement Information

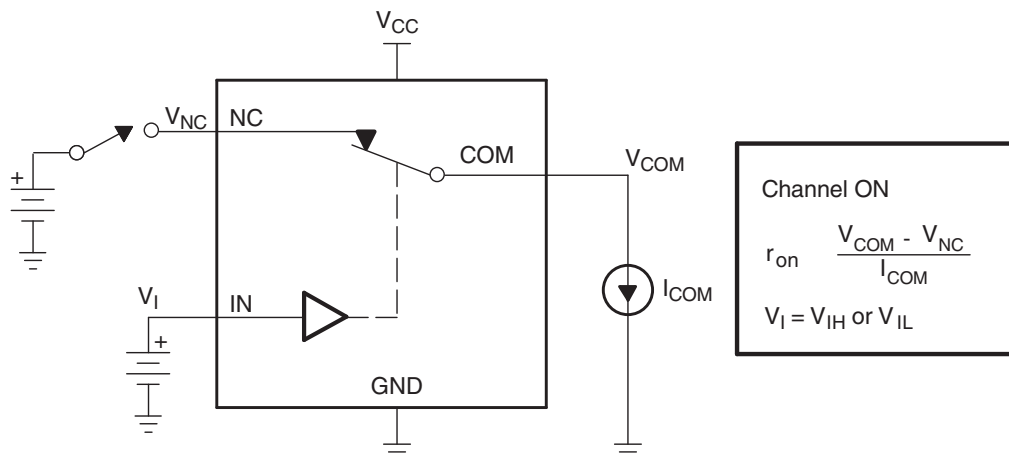

Figure 13. ON-State Resistance (r_{on})

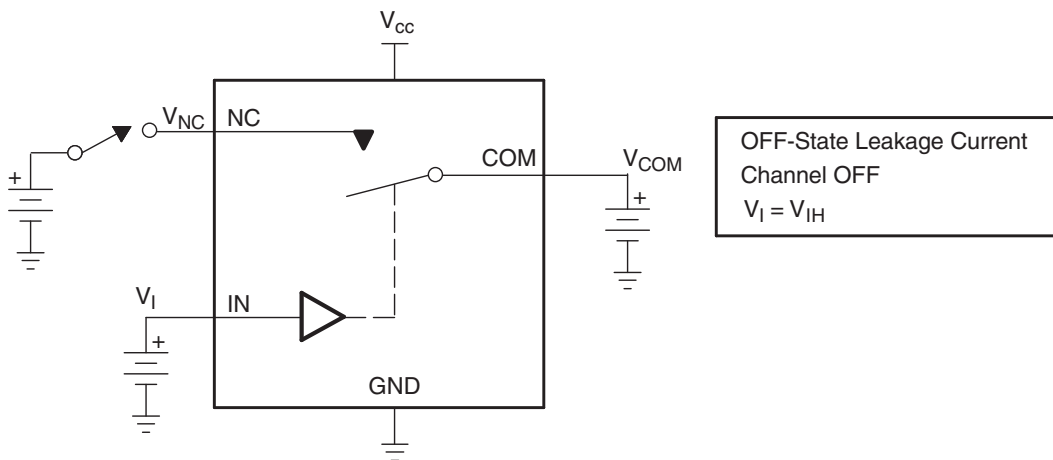

Figure 14. OFF-State Leakage Current ($I_{COM(OFF)}$, $I_{NC(OFF)}$, $I_{COM(PWROFF)}$, $I_{NC(PWROFF)}$)

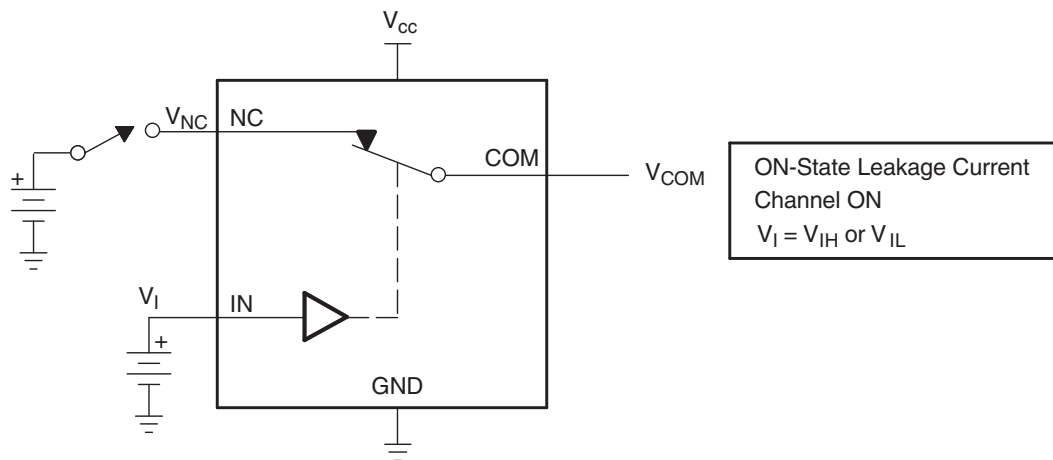

Figure 15. ON-State Leakage Current ($I_{COM(ON)}$, $I_{NC(ON)}$)

Parameter Measurement Information (continued)

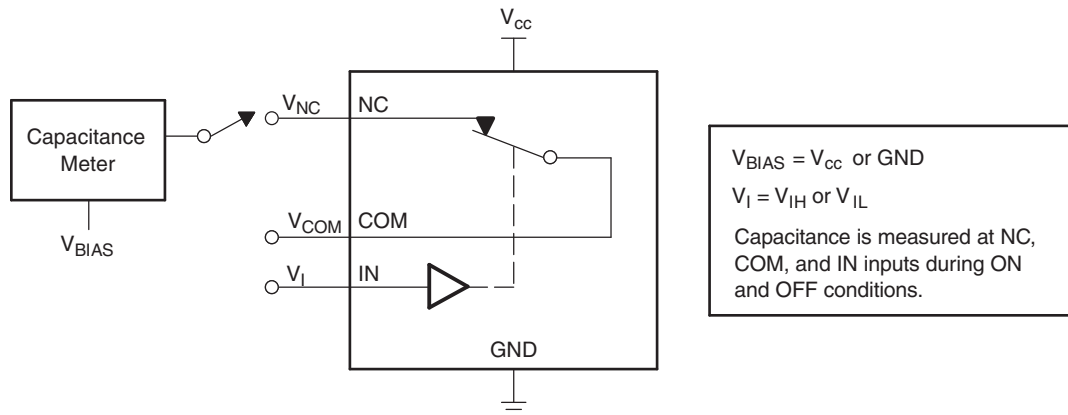
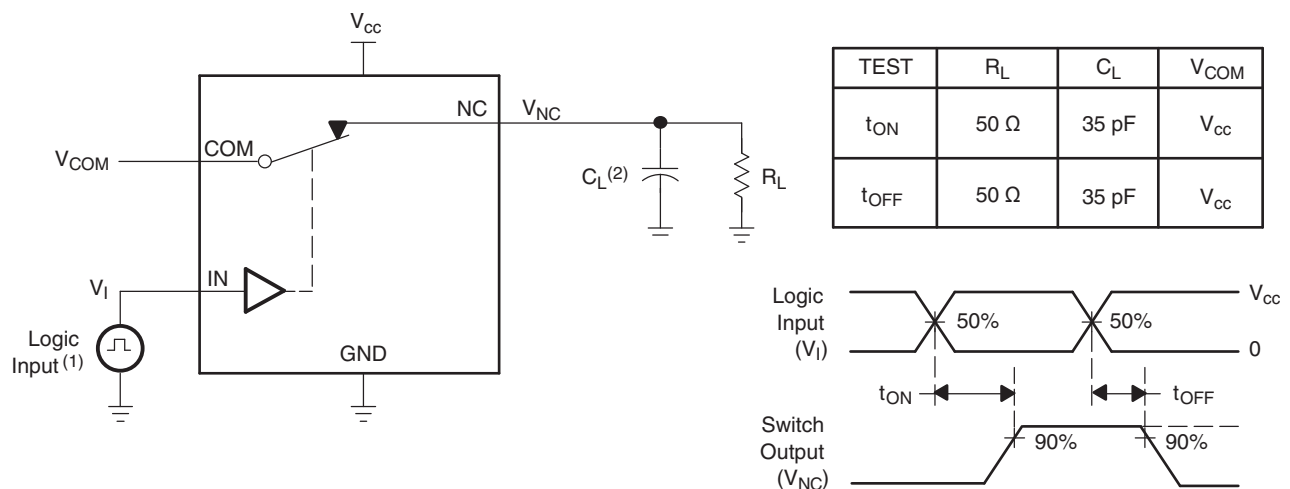

Figure 16. Capacitance (C_I , $C_{COM(OFF)}$, $C_{COM(ON)}$, $C_{NC(OFF)}$, $C_{NC(ON)}$)



- (1) All input pulses are supplied by generators having the following characteristics: PRR \leq 10 MHz, $Z_O = 50 \Omega$, $t_r < 5$ ns, $t_f < 5$ ns.
- (2) C_L includes probe and jig capacitance.

Figure 17. Turn-On (t_{ON}) and Turn-Off Time (t_{OFF})

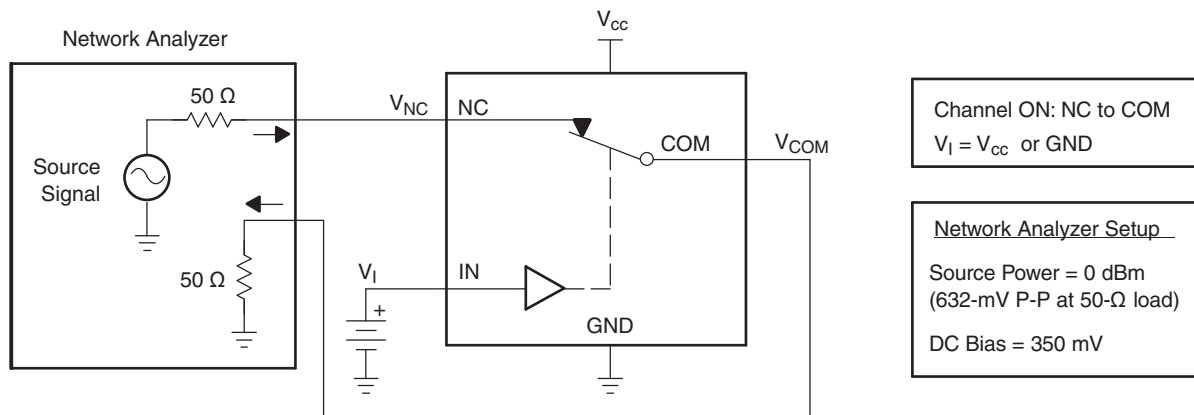

Figure 18. Bandwidth (BW)

Parameter Measurement Information (continued)

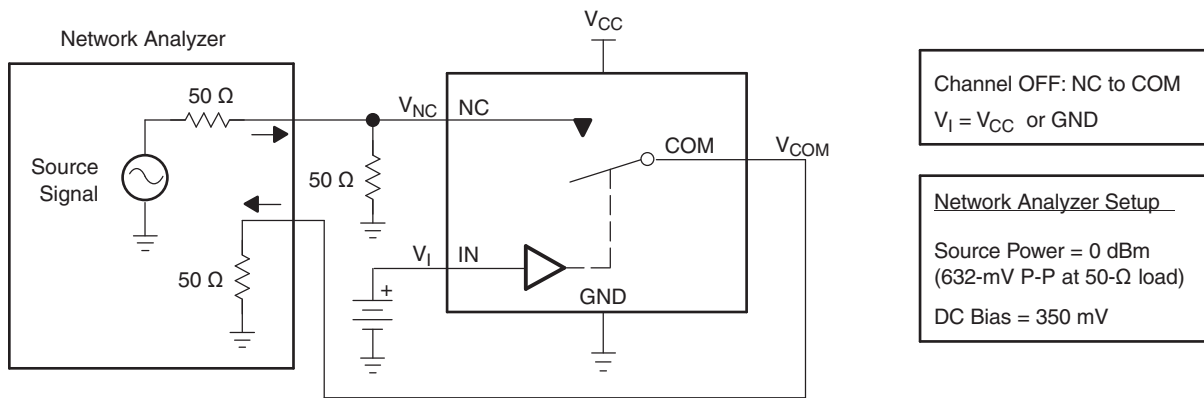
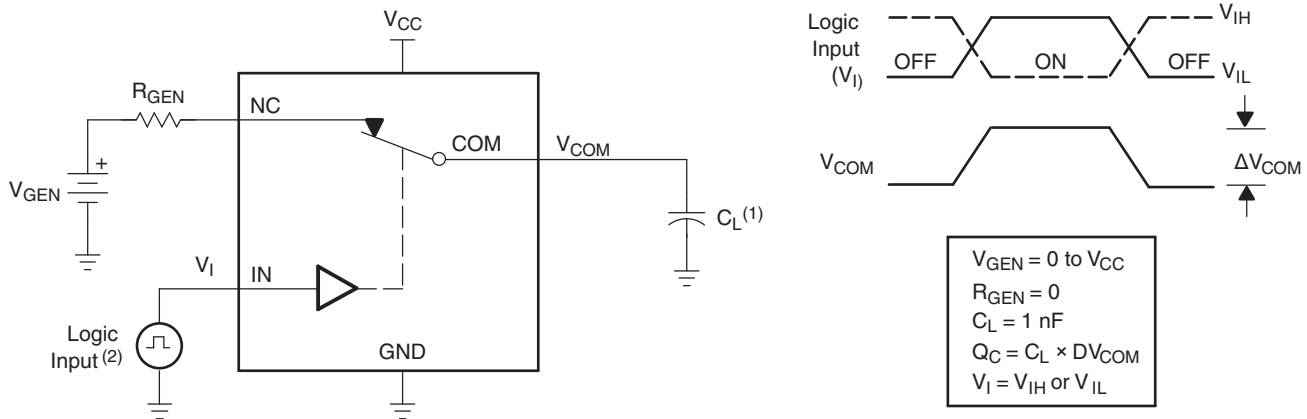
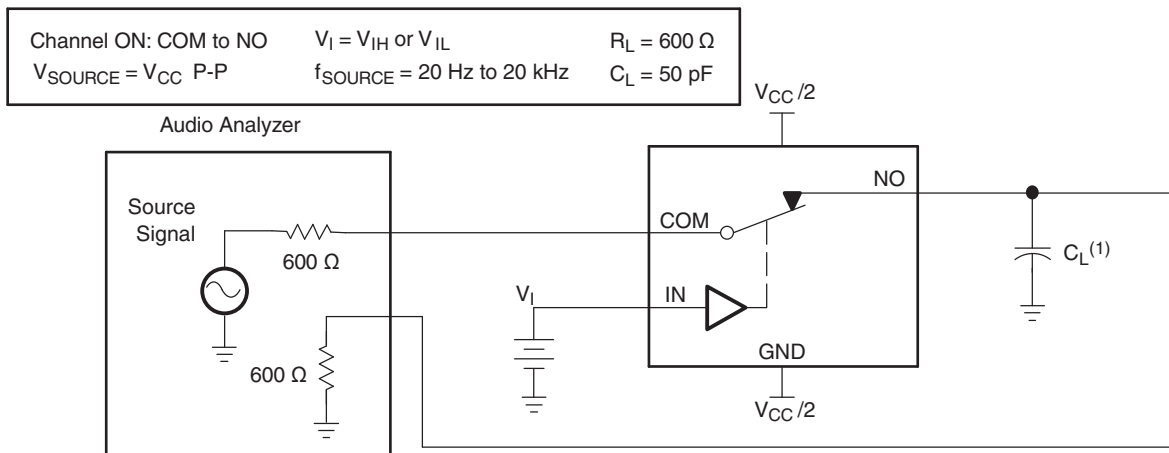

Figure 19. OFF Isolation (O_{Iso})



- (1) C_L includes probe and jig capacitance.
- (2) All input pulses are supplied by generators having the following characteristics: $PRR \leq 10$ MHz, $Z_O = 50 \Omega$, $t_r < 5$ ns, $t_f < 5$ ns.

Figure 20. Charge Injection (Q_C)



- (1) C_L includes probe and jig capacitance.

Figure 21. Total Harmonic Distortion (THD)

8 Detailed Description

8.1 Overview

The TS5A3167 is a bidirectional, single-channel, single-pole single-throw (SPST) analog switch that is designed to operate from 1.65 V to 5.5 V. This device provides a signal switching solution while maintaining excellent signal integrity, which makes the TS5A3167 suitable for a wide range of applications in various markets including personal electronics, portable instrumentation, and test and measurement equipment. The device maintains the signal integrity by its low ON-state resistance, excellent ON-state resistance matching, and total harmonic distortion (THD) performance. The device consumes very low power and provides isolation when $V_{CC} = 0$.

8.2 Functional Block Diagram

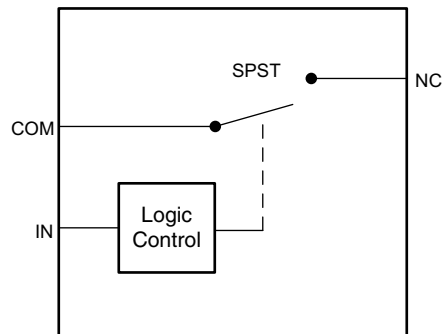

8.3 Feature Description

8.3.1 Isolation in Powered-Off Mode, $V_{CC} = 0$

When power is not supplied to the V_{CC} pin, $V_{CC} = 0$, the signal paths NC and COM are high impedance. This is specified in the electrical characteristics table under the COM and NC OFF leakage current when $V_{CC} = 0$. Because the device is high impedance when it is not powered, you may connect other signals to the signal chain without interference of the TS5A3167.

8.4 Device Functional Modes

Placing a logic low signal on the IN pin of the device will turn on the switch and provide a low impedance path from NC to COM.

Table 1. Function Table

| IN | NC TO COM, COM TO NC |
|----|-------------------------|
| L | ON |
| H | OFF |

9 Application and Implementation

NOTE

Information in the following applications sections is not part of the TI component specification, and TI does not warrant its accuracy or completeness. TI's customers are responsible for determining suitability of components for their purposes. Customers should validate and test their design implementation to confirm system functionality.

9.1 Application Information

The TS5A3167 switch is bidirectional, so the NC and COM pins can be used as either inputs or outputs. This switch is typically used when there is one signal path that needs to be isolated at certain times.

9.2 Typical Application

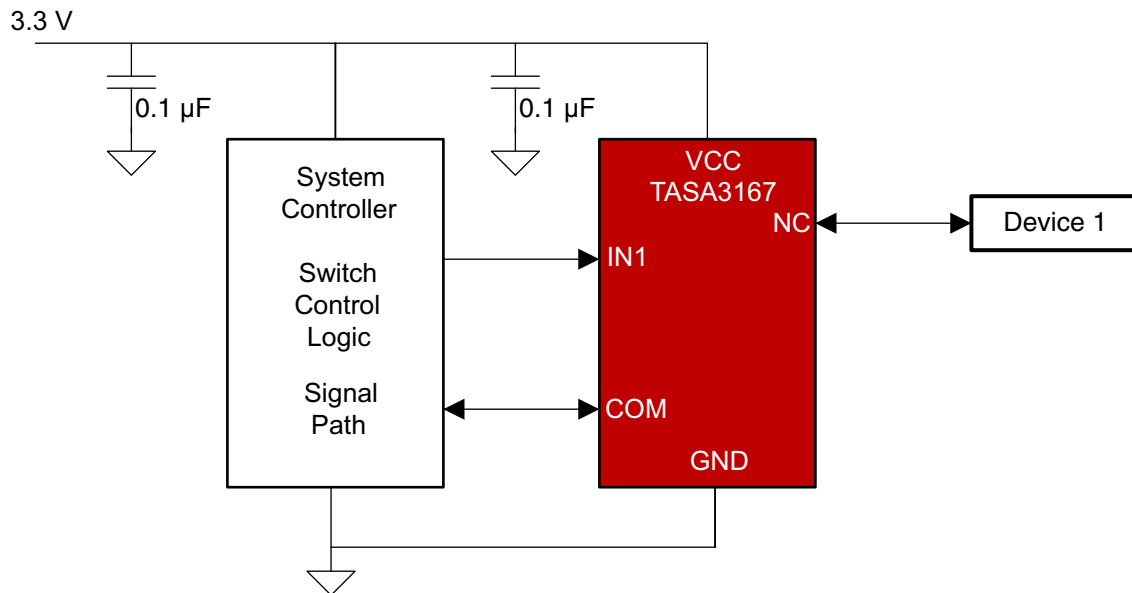

Copyright © 2017, Texas Instruments Incorporated

Figure 22. Typical Application

9.2.1 Design Requirements

The TS5A3167 device can be properly operated without any external components.

Unused pin may be left floating or connected to ground.

TI recommends pulling up the digital control pin (IN) to V_{CC} or pulling down to GND to avoid undesired switch positions that could result from the floating pin. A floating digital pin could cause excess current consumption refer to [Implications of Slow or Floating CMOS Inputs](#).

9.2.2 Detailed Design Procedure

Select the appropriate supply voltage to cover the entire voltage swing of the signal passing through the switch because the TS5A3167 input and output signal swing through NC and COM are dependent on the supply voltage V_{CC} . For example, if the desired signal level to pass through the switch is 5 V, V_{CC} must be greater than or equal to 5 V. $V_{CC} = 3.3$ V would not be valid for passing a 5-V signal since the analog signal voltage cannot exceed the supply.

Typical Application (continued)

9.2.3 Application Curves

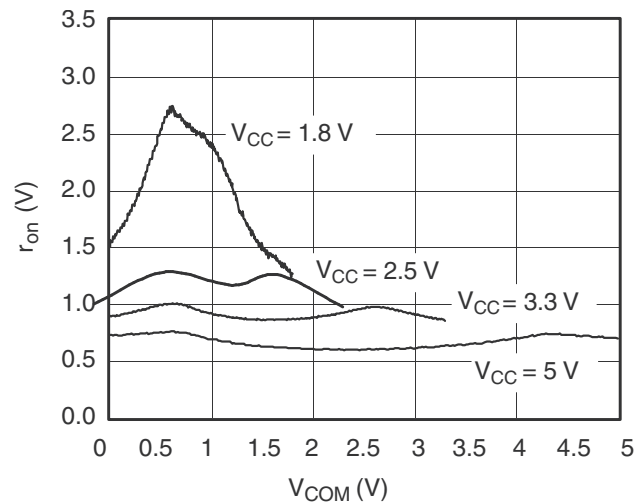

Figure 23. r_{on} vs V_{COM}

10 Power Supply Recommendations

TI recommends proper power-supply sequencing for all CMOS devices. Do not exceed the absolute maximum ratings, because stresses beyond the listed ratings can cause permanent damage to the device. It is recommended that V_{CC} is powered on first, followed by NC or COM but not required because of the Isolation in Powered-Off Mode, $V_{CC} = 0$ feature.

Although it is not required, power-supply bypassing improves noise margin and prevents switching noise propagation from the V_{CC} supply to other components. A 0.1- μ F capacitor, connected from V_{CC} to GND, is adequate for most applications.

11 Layout

11.1 Layout Guidelines

TI recommends following common printed-circuit board layout guidelines to ensure reliability of the device.

- Bypass capacitors should be used on power supplies.
- Short trace lengths should be used to avoid excessive loading.

11.2 Layout Example

 = VIA to GND Plane

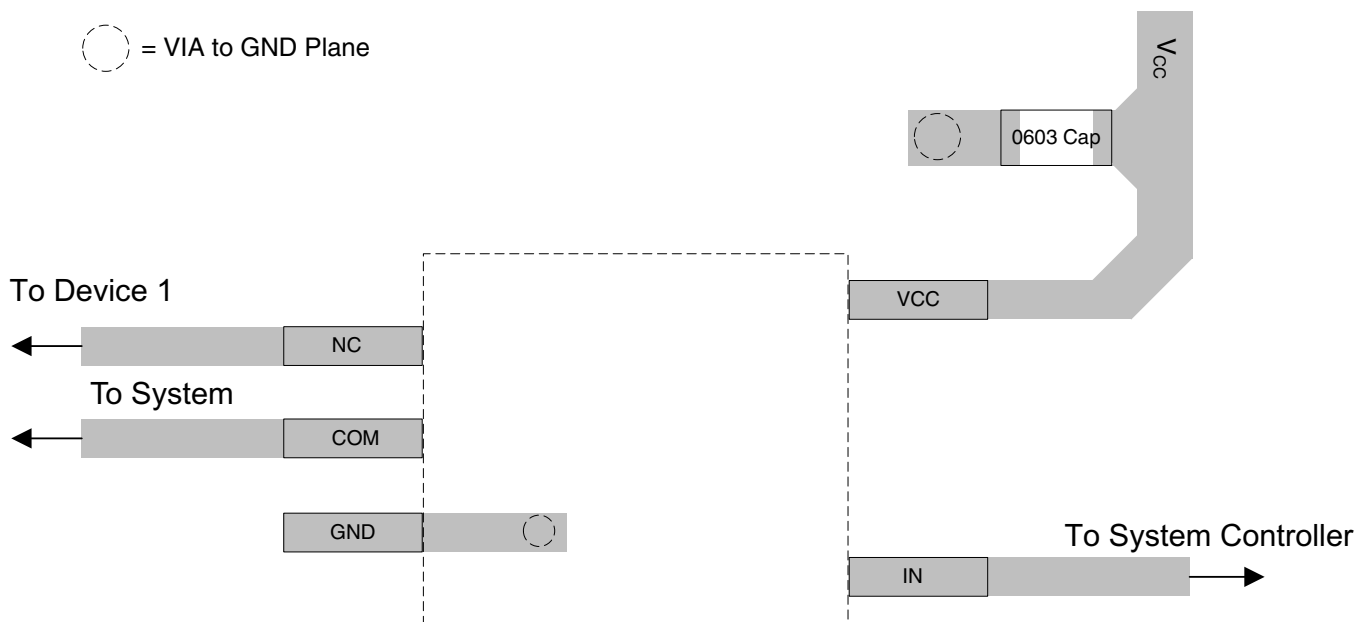

Figure 24. Example Layout

12 Device and Documentation Support

12.1 Documentation Support

Table 2. Parameter Description

| SYMBOL | DESCRIPTION |
|-------------------|--|
| V_{COM} | Voltage at COM. |
| V_{NC} | Voltage at NC. |
| r_{on} | Resistance between COM and NC ports when the channel is ON. |
| r_{peak} | Peak on-state resistance over a specified voltage range. |
| $r_{on(flat)}$ | Difference between the maximum and minimum value of r_{on} in a channel over the specified range of conditions. |
| $I_{NC(OFF)}$ | Leakage current measured at the NC port, with the corresponding channel (NC to COM) in the OFF state under worst-case input and output conditions. |
| $I_{NC(PWROFF)}$ | Leakage current measured at the NC port during the power-down condition, $V_{CC} = 0$. |
| $I_{COM(OFF)}$ | Leakage current measured at the COM port, with the corresponding channel (COM to NC) in the OFF state under worst-case input and output conditions. |
| $I_{COM(PWROFF)}$ | Leakage current measured at the COM port during the power-down condition, $V_{CC} = 0$. |
| $I_{NC(ON)}$ | Leakage current measured at the NC port, with the corresponding channel (NC to COM) in the ON state and the output (COM) open. |
| $I_{COM(ON)}$ | Leakage current measured at the COM port, with the corresponding channel (COM to NC) in the ON state and the output (NC) open. |
| V_{IH} | Minimum input voltage for logic high for the control input (IN). |
| V_{IL} | Maximum input voltage for logic low for the control input (IN). |
| V_I | Voltage at the control input (IN). |
| I_{IH}, I_{IL} | Leakage current measured at the control input (IN). |
| t_{ON} | Turn-on time for the switch. This parameter is measured under the specified range of conditions and by the propagation delay between the digital control (IN) signal and analog output (COM or NC) signal when the switch is turning ON. |
| t_{OFF} | Turn-off time for the switch. This parameter is measured under the specified range of conditions and by the propagation delay between the digital control (IN) signal and analog output (COM or NC) signal when the switch is turning OFF. |
| Q_C | Charge injection is a measurement of unwanted signal coupling from the control (IN) input to the analog (NC or COM) output. This is measured in coulombs (C) and measured by the total charge induced due to switching of the control input. Charge injection, $Q_C = C_L \times \Delta V_{COM}$, C_L is the load capacitance, and ΔV_{COM} is the change in analog output voltage. |
| $C_{NC(OFF)}$ | Capacitance at the NC port when the corresponding channel (NC to COM) is OFF. |
| $C_{COM(OFF)}$ | Capacitance at the COM port when the corresponding channel (COM to NC) is OFF. |
| $C_{NC(ON)}$ | Capacitance at the NC port when the corresponding channel (NC to COM) is ON. |
| $C_{COM(ON)}$ | Capacitance at the COM port when the corresponding channel (COM to NC) is ON. |
| C_I | Capacitance of control input (IN). |
| O_{ISO} | OFF isolation of the switch is a measurement of OFF-state switch impedance. This is measured in dB in a specific frequency, with the corresponding channel (NC to COM) in the OFF state. |
| BW | Bandwidth of the switch. This is the frequency in which the gain of an ON channel is –3 dB below the DC gain. |
| THD | Total harmonic distortion describes the signal distortion caused by the analog switch. This is defined as the ratio of root mean square (RMS) value of the second, third, and higher harmonic to the absolute magnitude of the fundamental harmonic. |
| I_{CC} | Static power-supply current with the control (IN) pin at V_{CC} or GND. |

12.2 Receiving Notification of Documentation Updates

To receive notification of documentation updates, navigate to the device product folder on ti.com. In the upper right corner, click on *Alert me* to register and receive a weekly digest of any product information that has changed. For change details, review the revision history included in any revised document.

12.3 Community Resources

The following links connect to TI community resources. Linked contents are provided "AS IS" by the respective contributors. They do not constitute TI specifications and do not necessarily reflect TI's views; see TI's [Terms of Use](#).

Community Resources (continued)

TI E2E™ Online Community *TI's Engineer-to-Engineer (E2E) Community*. Created to foster collaboration among engineers. At e2e.ti.com, you can ask questions, share knowledge, explore ideas and help solve problems with fellow engineers.

Design Support *TI's Design Support* Quickly find helpful E2E forums along with design support tools and contact information for technical support.

12.4 Trademarks

E2E is a trademark of Texas Instruments.

12.5 Electrostatic Discharge Caution



This integrated circuit can be damaged by ESD. Texas Instruments recommends that all integrated circuits be handled with appropriate precautions. Failure to observe proper handling and installation procedures can cause damage.

ESD damage can range from subtle performance degradation to complete device failure. Precision integrated circuits may be more susceptible to damage because very small parametric changes could cause the device not to meet its published specifications.

12.6 Glossary

SLYZ022 — *TI Glossary*.

This glossary lists and explains terms, acronyms, and definitions.

13 Mechanical, Packaging, and Orderable Information

The following pages include mechanical, packaging, and orderable information. This information is the most current data available for the designated devices. This data is subject to change without notice and revision of this document. For browser-based versions of this data sheet, refer to the left-hand navigation.

PACKAGING INFORMATION

| Orderable Device | Status (1) | Package Type | Package Drawing | Pins | Package Qty | Eco Plan (2) | Lead finish/ Ball material (6) | MSL Peak Temp (3) | Op Temp (°C) | Device Marking (4/5) | Samples |
|------------------|---------------|--------------|-----------------|------|-------------|-----------------|--------------------------------------|----------------------|--------------|------------------------------------|-------------------------|
| TS5A3167DBVR | ACTIVE | SOT-23 | DBV | 5 | 3000 | RoHS & Green | NIPDAU SN | Level-1-260C-UNLIM | -40 to 85 | (JATF, JATR) (JATH, JATP) | Samples |
| TS5A3167DBVRE4 | ACTIVE | SOT-23 | DBV | 5 | 3000 | RoHS & Green | NIPDAU | Level-1-260C-UNLIM | -40 to 85 | JATF | Samples |
| TS5A3167DBVRG4 | ACTIVE | SOT-23 | DBV | 5 | 3000 | RoHS & Green | NIPDAU | Level-1-260C-UNLIM | -40 to 85 | JATF | Samples |
| TS5A3167DCKR | ACTIVE | SC70 | DCK | 5 | 3000 | RoHS & Green | NIPDAU | Level-1-260C-UNLIM | -40 to 85 | (JG5, JGF, JGR) (JGH, JGP, JGS) | Samples |
| TS5A3167DCKRG4 | ACTIVE | SC70 | DCK | 5 | 3000 | RoHS & Green | NIPDAU | Level-1-260C-UNLIM | -40 to 85 | (JG5, JGF, JGR) (JGH, JGP, JGS) | Samples |
| TS5A3167YZPR | ACTIVE | DSBGA | YZP | 5 | 3000 | RoHS & Green | SNAGCU | Level-1-260C-UNLIM | -40 to 85 | JGN | Samples |

(1) The marketing status values are defined as follows:

ACTIVE: Product device recommended for new designs.

LIFEBUY: TI has announced that the device will be discontinued, and a lifetime-buy period is in effect.

NRND: Not recommended for new designs. Device is in production to support existing customers, but TI does not recommend using this part in a new design.

PREVIEW: Device has been announced but is not in production. Samples may or may not be available.

OBSELETE: TI has discontinued the production of the device.

(2) **RoHS:** TI defines "RoHS" to mean semiconductor products that are compliant with the current EU RoHS requirements for all 10 RoHS substances, including the requirement that RoHS substance do not exceed 0.1% by weight in homogeneous materials. Where designed to be soldered at high temperatures, "RoHS" products are suitable for use in specified lead-free processes. TI may reference these types of products as "Pb-Free".

RoHS Exempt: TI defines "RoHS Exempt" to mean products that contain lead but are compliant with EU RoHS pursuant to a specific EU RoHS exemption.

Green: TI defines "Green" to mean the content of Chlorine (Cl) and Bromine (Br) based flame retardants meet JS709B low halogen requirements of <=1000ppm threshold. Antimony trioxide based flame retardants must also meet the <=1000ppm threshold requirement.

(3) MSL, Peak Temp. - The Moisture Sensitivity Level rating according to the JEDEC industry standard classifications, and peak solder temperature.

(4) There may be additional marking, which relates to the logo, the lot trace code information, or the environmental category on the device.

(5) Multiple Device Markings will be inside parentheses. Only one Device Marking contained in parentheses and separated by a "-" will appear on a device. If a line is indented then it is a continuation of the previous line and the two combined represent the entire Device Marking for that device.

⁽⁶⁾ Lead finish/Ball material - Orderable Devices may have multiple material finish options. Finish options are separated by a vertical ruled line. Lead finish/Ball material values may wrap to two lines if the finish value exceeds the maximum column width.

Important Information and Disclaimer:The information provided on this page represents TI's knowledge and belief as of the date that it is provided. TI bases its knowledge and belief on information provided by third parties, and makes no representation or warranty as to the accuracy of such information. Efforts are underway to better integrate information from third parties. TI has taken and continues to take reasonable steps to provide representative and accurate information but may not have conducted destructive testing or chemical analysis on incoming materials and chemicals. TI and TI suppliers consider certain information to be proprietary, and thus CAS numbers and other limited information may not be available for release.

In no event shall TI's liability arising out of such information exceed the total purchase price of the TI part(s) at issue in this document sold by TI to Customer on an annual basis.

TAPE AND REEL INFORMATION

QUADRANT ASSIGNMENTS FOR PIN 1 ORIENTATION IN TAPE

*All dimensions are nominal

| Device | Package Type | Package Drawing | Pins | SPQ | Reel Diameter (mm) | Reel Width W1 (mm) | A0 (mm) | B0 (mm) | K0 (mm) | P1 (mm) | W (mm) | Pin1 Quadrant |
|----------------|--------------|-----------------|------|------|--------------------|--------------------|---------|---------|---------|---------|--------|---------------|
| TS5A3167DBVR | SOT-23 | DBV | 5 | 3000 | 180.0 | 8.4 | 3.23 | 3.17 | 1.37 | 4.0 | 8.0 | Q3 |
| TS5A3167DBVR | SOT-23 | DBV | 5 | 3000 | 178.0 | 9.0 | 3.23 | 3.17 | 1.37 | 4.0 | 8.0 | Q3 |
| TS5A3167DBVRG4 | SOT-23 | DBV | 5 | 3000 | 178.0 | 9.0 | 3.23 | 3.17 | 1.37 | 4.0 | 8.0 | Q3 |
| TS5A3167DCKR | SC70 | DCK | 5 | 3000 | 180.0 | 8.4 | 2.47 | 2.3 | 1.25 | 4.0 | 8.0 | Q3 |
| TS5A3167DCKR | SC70 | DCK | 5 | 3000 | 178.0 | 9.2 | 2.4 | 2.4 | 1.22 | 4.0 | 8.0 | Q3 |
| TS5A3167YZPR | DSBGA | YZP | 5 | 3000 | 178.0 | 9.2 | 1.02 | 1.52 | 0.63 | 4.0 | 8.0 | Q1 |

TAPE AND REEL BOX DIMENSIONS

*All dimensions are nominal

| Device | Package Type | Package Drawing | Pins | SPQ | Length (mm) | Width (mm) | Height (mm) |
|----------------|--------------|-----------------|------|------|-------------|------------|-------------|
| TS5A3167DBVR | SOT-23 | DBV | 5 | 3000 | 202.0 | 201.0 | 28.0 |
| TS5A3167DBVR | SOT-23 | DBV | 5 | 3000 | 180.0 | 180.0 | 18.0 |
| TS5A3167DBVRG4 | SOT-23 | DBV | 5 | 3000 | 180.0 | 180.0 | 18.0 |
| TS5A3167DCKR | SC70 | DCK | 5 | 3000 | 202.0 | 201.0 | 28.0 |
| TS5A3167DCKR | SC70 | DCK | 5 | 3000 | 180.0 | 180.0 | 18.0 |
| TS5A3167YZPR | DSBGA | YZP | 5 | 3000 | 220.0 | 220.0 | 35.0 |

DBV0005A



PACKAGE OUTLINE

SOT-23 - 1.45 mm max height

SMALL OUTLINE TRANSISTOR

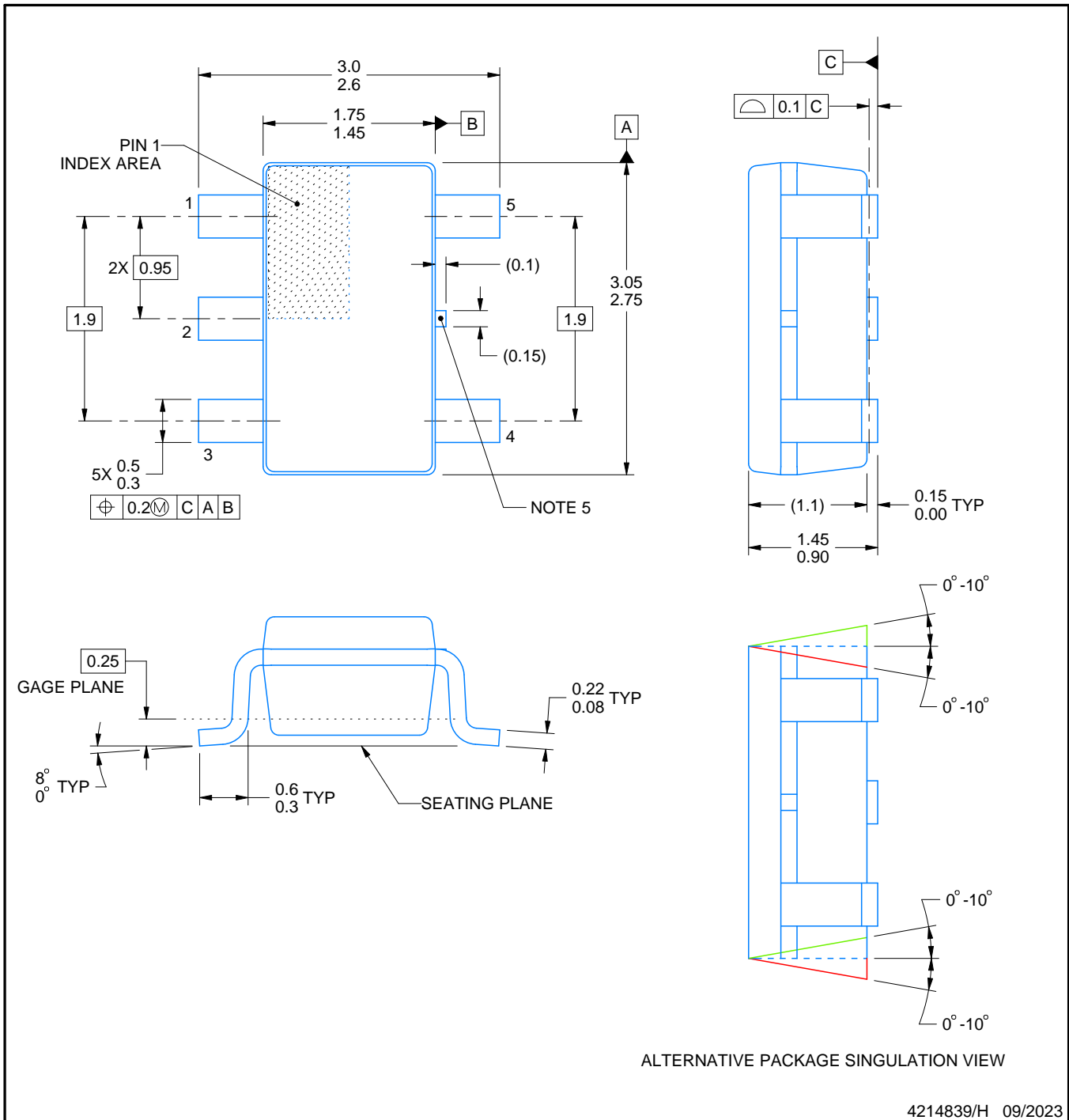

NOTES:

1. All linear dimensions are in millimeters. Any dimensions in parenthesis are for reference only. Dimensioning and tolerancing per ASME Y14.5M.
2. This drawing is subject to change without notice.
3. Reference JEDEC MO-178.
4. Body dimensions do not include mold flash, protrusions, or gate burrs. Mold flash, protrusions, or gate burrs shall not exceed 0.25 mm per side.
5. Support pin may differ or may not be present.

EXAMPLE BOARD LAYOUT

DBV0005A

SOT-23 - 1.45 mm max height

SMALL OUTLINE TRANSISTOR

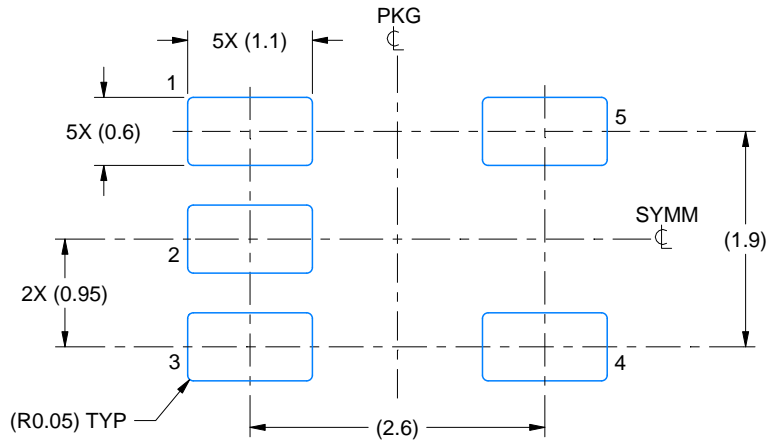

LAND PATTERN EXAMPLE
EXPOSED METAL SHOWN
SCALE:15X

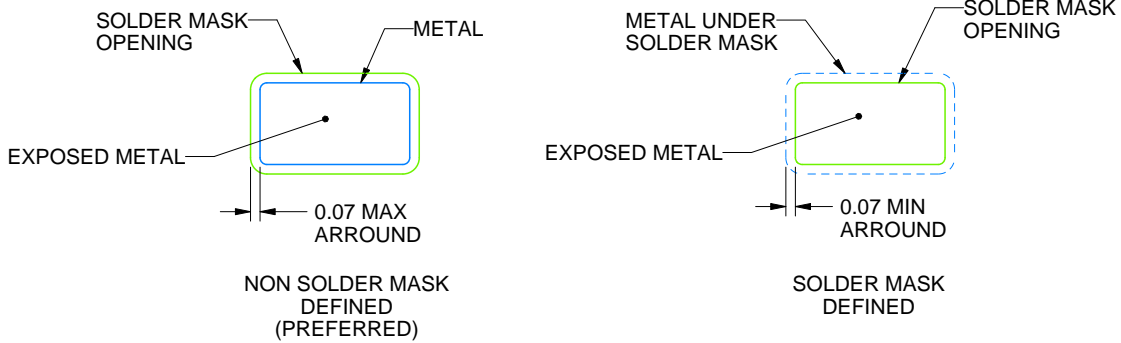

SOLDER MASK DETAILS

4214839/H 09/2023

NOTES: (continued)

- 6. Publication IPC-7351 may have alternate designs.
- 7. Solder mask tolerances between and around signal pads can vary based on board fabrication site.

EXAMPLE STENCIL DESIGN

DBV0005A

SOT-23 - 1.45 mm max height

SMALL OUTLINE TRANSISTOR

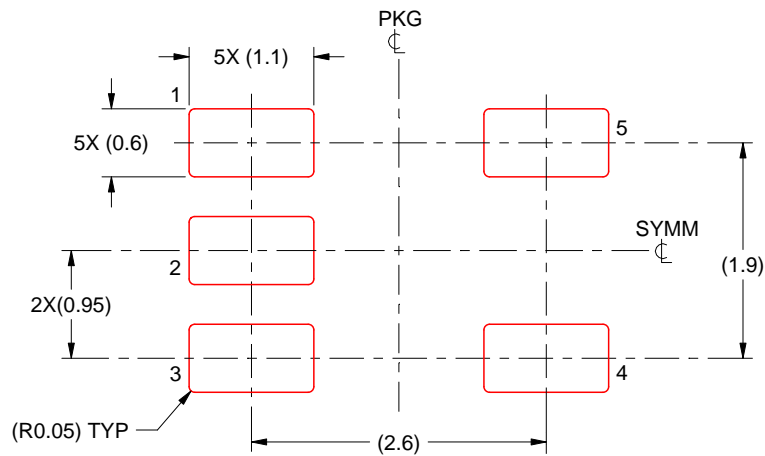

SOLDER PASTE EXAMPLE
BASED ON 0.125 mm THICK STENCIL
SCALE:15X

4214839/H 09/2023

NOTES: (continued)

8. Laser cutting apertures with trapezoidal walls and rounded corners may offer better paste release. IPC-7525 may have alternate design recommendations.
9. Board assembly site may have different recommendations for stencil design.

EXAMPLE BOARD LAYOUT

DCK0005A

SOT - 1.1 max height

SMALL OUTLINE TRANSISTOR

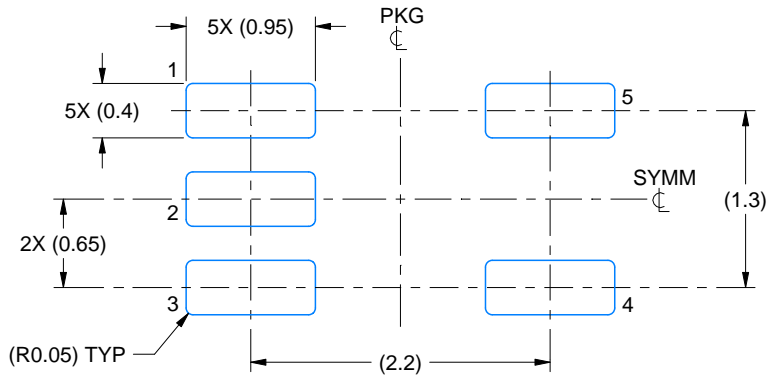

LAND PATTERN EXAMPLE
EXPOSED METAL SHOWN
SCALE:18X

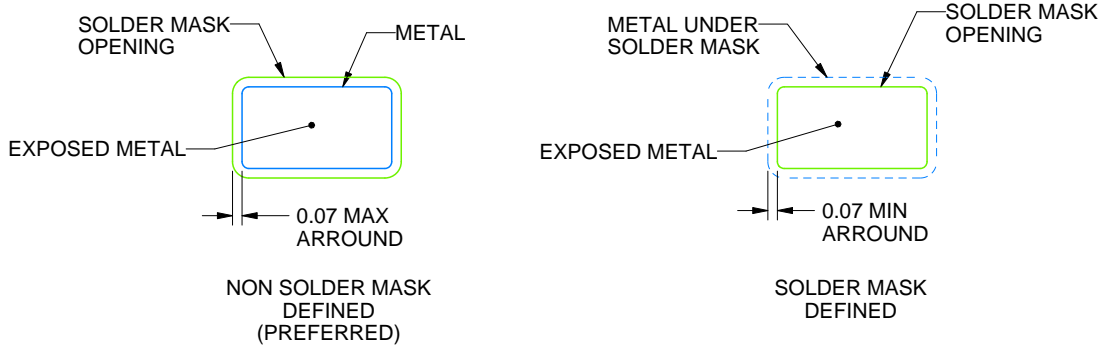

SOLDER MASK DETAILS

4214834/C 03/2023

NOTES: (continued)

- 4. Publication IPC-7351 may have alternate designs.
- 5. Solder mask tolerances between and around signal pads can vary based on board fabrication site.

EXAMPLE STENCIL DESIGN

DCK0005A

SOT - 1.1 max height

SMALL OUTLINE TRANSISTOR

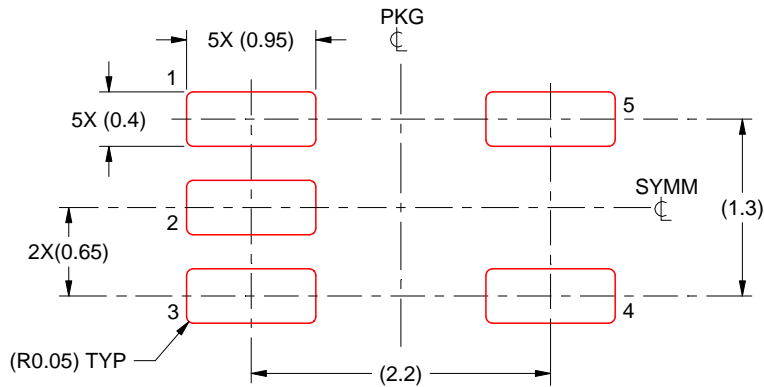

SOLDER PASTE EXAMPLE
BASED ON 0.125 THICK STENCIL
SCALE:18X

4214834/C 03/2023

NOTES: (continued)

6. Laser cutting apertures with trapezoidal walls and rounded corners may offer better paste release. IPC-7525 may have alternate design recommendations.
7. Board assembly site may have different recommendations for stencil design.

YZP0005

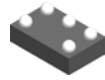

PACKAGE OUTLINE

DSBGA - 0.5 mm max height

DIE SIZE BALL GRID ARRAY

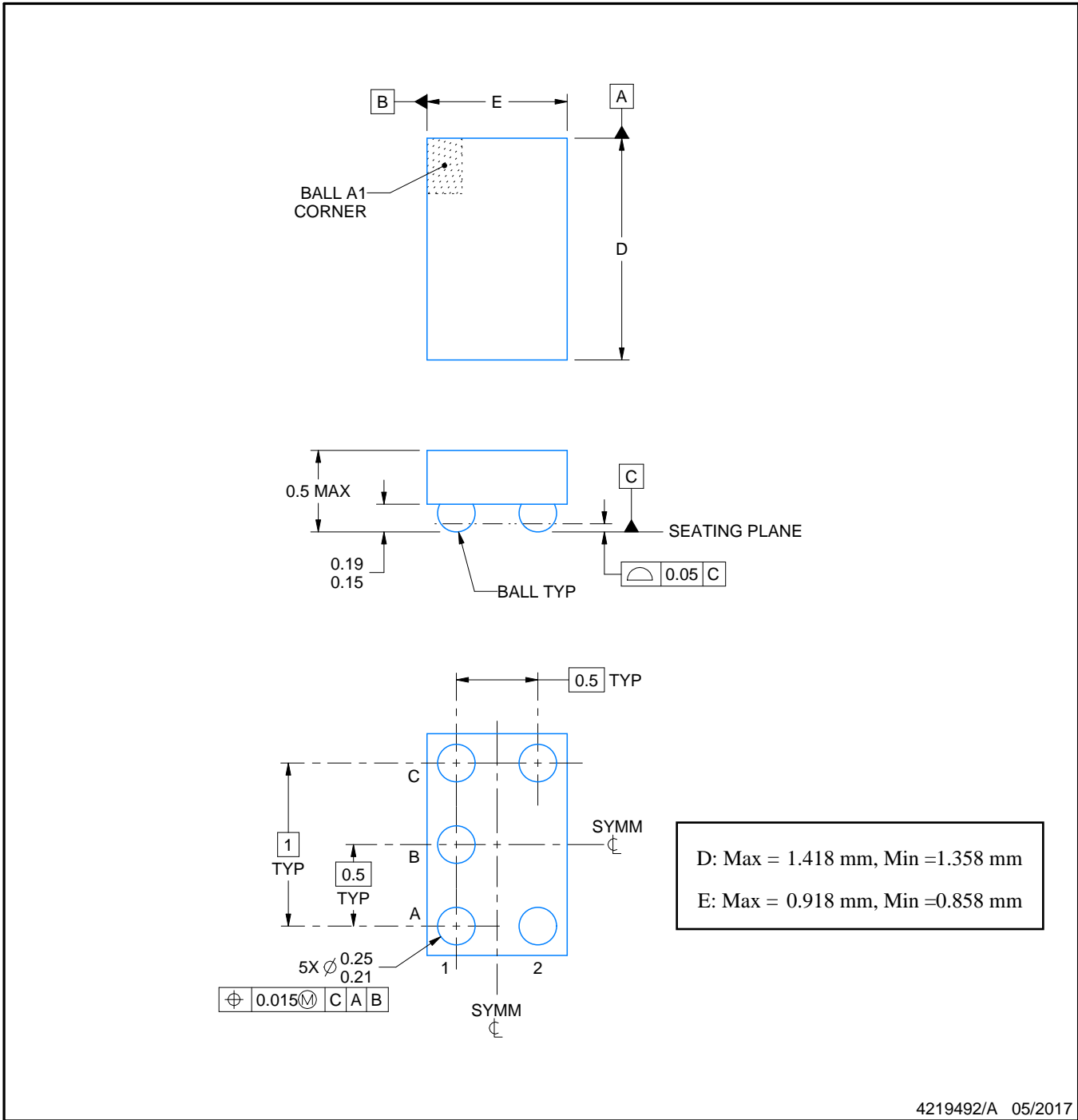

NOTES:

1. All linear dimensions are in millimeters. Any dimensions in parenthesis are for reference only. Dimensioning and tolerancing per ASME Y14.5M.
2. This drawing is subject to change without notice.

EXAMPLE BOARD LAYOUT

YZP0005

DSBGA - 0.5 mm max height

DIE SIZE BALL GRID ARRAY



LAND PATTERN EXAMPLE
SCALE:40X



SOLDER MASK DETAILS
NOT TO SCALE

4219492/A 05/2017

NOTES: (continued)

3. Final dimensions may vary due to manufacturing tolerance considerations and also routing constraints. For more information, see Texas Instruments literature number SNVA009 (www.ti.com/lit/snva009).

EXAMPLE STENCIL DESIGN

YZP0005

DSBGA - 0.5 mm max height

DIE SIZE BALL GRID ARRAY



SOLDER PASTE EXAMPLE
BASED ON 0.1 mm THICK STENCIL
SCALE:40X

4219492/A 05/2017

NOTES: (continued)

4. Laser cutting apertures with trapezoidal walls and rounded corners may offer better paste release.

IMPORTANT NOTICE AND DISCLAIMER

TI PROVIDES TECHNICAL AND RELIABILITY DATA (INCLUDING DATA SHEETS), DESIGN RESOURCES (INCLUDING REFERENCE DESIGNS), APPLICATION OR OTHER DESIGN ADVICE, WEB TOOLS, SAFETY INFORMATION, AND OTHER RESOURCES "AS IS" AND WITH ALL FAULTS, AND DISCLAIMS ALL WARRANTIES, EXPRESS AND IMPLIED, INCLUDING WITHOUT LIMITATION ANY IMPLIED WARRANTIES OF MERCHANTABILITY, FITNESS FOR A PARTICULAR PURPOSE OR NON-INFRINGEMENT OF THIRD PARTY INTELLECTUAL PROPERTY RIGHTS.

These resources are intended for skilled developers designing with TI products. You are solely responsible for (1) selecting the appropriate TI products for your application, (2) designing, validating and testing your application, and (3) ensuring your application meets applicable standards, and any other safety, security, regulatory or other requirements.

These resources are subject to change without notice. TI grants you permission to use these resources only for development of an application that uses the TI products described in the resource. Other reproduction and display of these resources is prohibited. No license is granted to any other TI intellectual property right or to any third party intellectual property right. TI disclaims responsibility for, and you will fully indemnify TI and its representatives against, any claims, damages, costs, losses, and liabilities arising out of your use of these resources.

TI's products are provided subject to [TI's Terms of Sale](#) or other applicable terms available either on [ti.com](https://www.ti.com) or provided in conjunction with such TI products. TI's provision of these resources does not expand or otherwise alter TI's applicable warranties or warranty disclaimers for TI products.

TI objects to and rejects any additional or different terms you may have proposed.

Mailing Address: Texas Instruments, Post Office Box 655303, Dallas, Texas 75265
Copyright © 2023, Texas Instruments Incorporated