

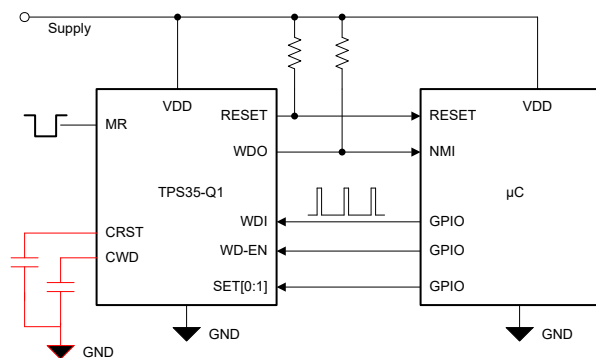
# TPS35-Q1 Automotive Nano IQ Precision Voltage Supervisor with Precision Timeout Watchdog Timer

## 1 Features

- AEC-Q100 qualified with the following results:
  - Device temperature grade 1:  $-40^{\circ}\text{C}$  to  $125^{\circ}\text{C}$  ambient operating temperature range
- Factory programmed or user-programmable watchdog timeout
  - $\pm 10\%$  Accurate timer (maximum)
  - Factory programmed: 1 msec to 100 sec
- Factory programmed or user-programmable reset delay
  - $\pm 10\%$  Accurate timer (maximum)
  - Factory programmed option: 2 msec to 10 sec
- Input voltage range:  $V_{DD} = 1.04\text{ V}$  to  $6.0\text{ V}$
- Fixed threshold voltage ( $V_{IT-}$ ):  $1.05\text{ V}$  to  $5.4\text{ V}$ 
  - Threshold voltage available in 50 mV steps
  - 1.2% Voltage threshold accuracy (maximum)
  - Built-in hysteresis ( $V_{HYS}$ ): 5% (typical)
- Ultra low supply current:  $I_{DD} = 250\text{ nA}$  (typical)
- Open-drain, push-pull; active-low outputs
- Various programmability options:
  - Watchdog enable-disable
  - Watchdog startup delay: no delay to 10 sec
  - On the fly timer extension: 1X to 256X
  - Latched output option
- $\overline{\text{MR}}$  functionality support

## 2 Applications

- [On-board \(OBC\) and wireless charger](#)
- [Driver monitoring](#)
- [Battery Management System \(BMS\)](#)
- [Front camera](#)
- [Surround view system ECU](#)



TPS35-Q1 offers various pinout options to support different features. Choose suitable pinout based on application needs

**Typical Application Circuit**

## 3 Description

The TPS35-Q1 is an ultra-low power consumption (250 nA typical) device offering a precision voltage supervisor with a programmable timeout watchdog timer. The TPS35-Q1 supports wide threshold levels for undervoltage supervision with 1.2% accuracy across the specified temperature range.

The TPS35-Q1 offers a high accuracy timeout watchdog timer with a host of features for a wide variety of applications. The timeout watchdog timer can be factory programmed or user programmed using an external capacitor. The timer value can be changed on-the-fly using a combination of logic pins. The watchdog also offers unique features such as enable-disable, start-up delay, independent WDO pin option.

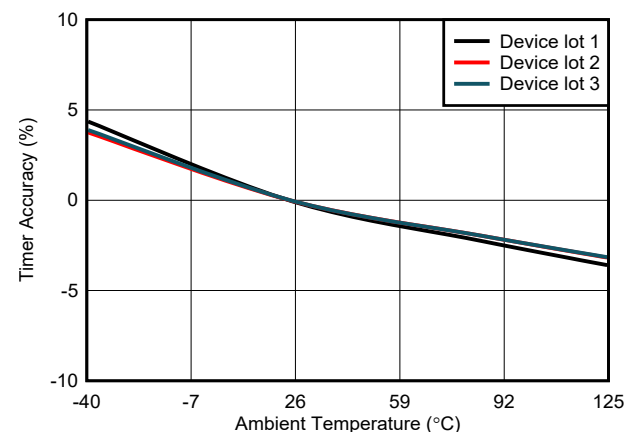
The  $\overline{\text{RESET}}$  or  $\overline{\text{WDO}}$  delay can be set by factory-programmed default delay settings or programmed by an external capacitor. The device also offers a latched output operation where the output is latched until the supervisor or watchdog fault is cleared.

The TPS35-Q1 provides a performance upgrade alternative to [TPS3851-Q1](#) device family. The TPS35-Q1 is available in a small 8-pin SOT-23 package.

### Device Information

PART NUMBER	PACKAGE <sup>(1)</sup>	BODY SIZE (NOM)
TPS35-Q1	DDF (8)	2.90 mm × 1.60 mm

- (1) For all available packages, see the orderable addendum at the end of the data sheet.



## Table of Contents

<b>1 Features</b> .....	1	8.2 Functional Block Diagrams.....	15
<b>2 Applications</b> .....	1	8.3 Feature Description.....	16
<b>3 Description</b> .....	1	8.4 Device Functional Modes.....	25
<b>4 Revision History</b> .....	2	<b>9 Application and Implementation</b> .....	26
<b>5 Device Comparison</b> .....	3	9.1 Application Information.....	26
<b>6 Pin Configuration and Functions</b> .....	4	9.2 Typical Applications.....	27
<b>7 Specifications</b> .....	6	<b>10 Power Supply Recommendations</b> .....	28
7.1 Absolute Maximum Ratings.....	6	<b>11 Layout</b> .....	29
7.2 ESD Ratings .....	6	11.1 Layout Guidelines.....	29
7.3 Recommended Operating Conditions.....	6	11.2 Layout Example.....	29
7.4 Thermal Information.....	7	<b>12 Device and Documentation Support</b> .....	30
7.5 Electrical Characteristics .....	8	12.1 Receiving Notification of Documentation Updates..	30
7.6 Timing Requirements .....	9	12.2 Support Resources.....	30
7.7 Switching Characteristics .....	10	12.3 Trademarks.....	31
7.8 Timing Diagrams.....	11	12.4 Electrostatic Discharge Caution.....	31
7.9 Typical Characteristics.....	12	12.5 Glossary.....	31
<b>8 Detailed Description</b> .....	15	<b>13 Mechanical, Packaging, and Orderable Information</b> .....	31
8.1 Overview.....	15		

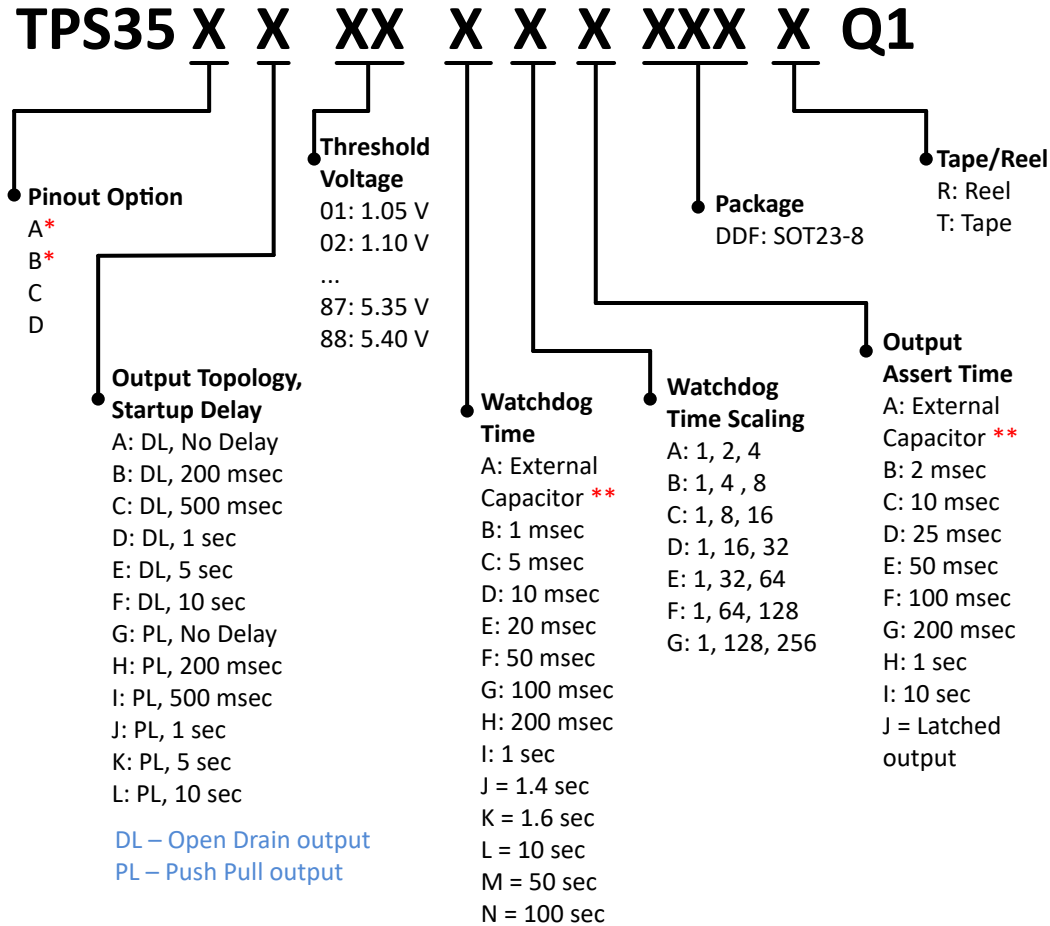
## 4 Revision History

NOTE: Page numbers for previous revisions may differ from page numbers in the current version.

Changes from Revision * (November 2022) to Revision A (June 2023)	Page
• Advance Information to Production Data release.....	1

## 5 Device Comparison

Figure 5-1 shows the device naming nomenclature of the TPS35-Q1. For all possible output types, threshold voltage options, watchdog time options and output assert delay options, see Section 8 for more details. Contact TI sales representatives or on TI's E2E forum for detail and availability of other options.



\* Pinout option supports Start up Delay settings of “No Delay” and “10 sec” only.

\*\* Capacitor programmable time feature available with pinout options A & B. For fixed time and latched output features use pinout options C & D.

Refer ‘Mechanical, Packaging and Orderable Information’ section for list of released orderable. For any other orderable, contact local TI support.

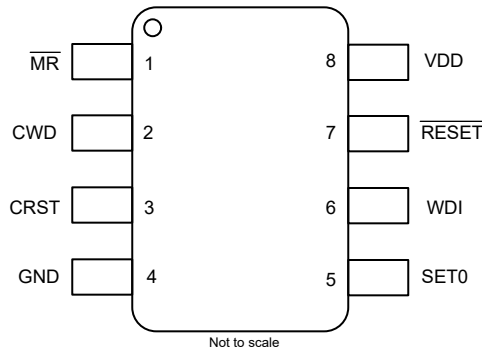
Figure 5-1. Device Naming Nomenclature

TPS35-Q1 belongs to family of pin compatible devices offering different feature sets as highlighted in Table 5-1.

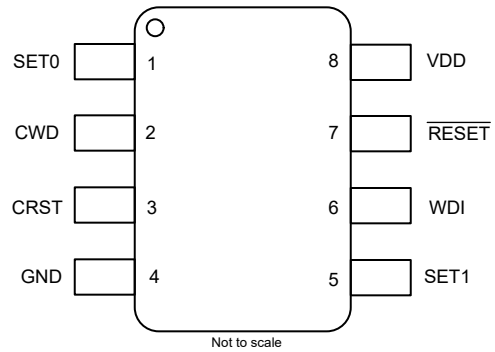
Table 5-1. Pin Compatible Device Families

DEVICE	VOLTAGE SUPERVISOR	TYPE OF WATCHDOG
TPS35-Q1	Yes	Timeout
TPS36-Q1	Yes	Window
TPS3435-Q1	No	Timeout
TPS3436-Q1	No	Window

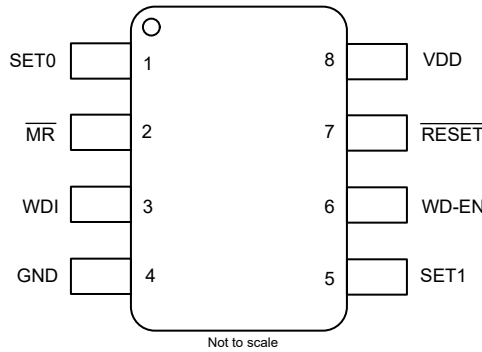
## 6 Pin Configuration and Functions



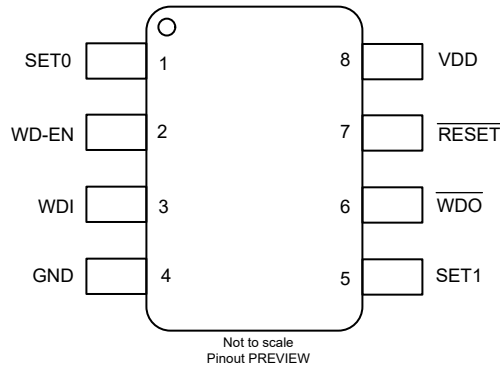
**Figure 6-1. Pin Configuration Option A**  
DDF Package, 8-Pin SOT-23,  
TPS35-Q1 Top View



**Figure 6-2. Pin Configuration Option B**  
DDF Package, 8-Pin SOT-23,  
TPS35-Q1 Top View



**Figure 6-3. Pin Configuration Option C**  
DDF Package, 8-Pin SOT-23,  
TPS35-Q1 Top View



**Figure 6-4. Pin Configuration Option D**  
DDF Package, 8-Pin SOT-23,  
TPS35-Q1 Top View

**Table 6-1. Pin Functions**

PIN NAME	PIN NUMBER				I/O	DESCRIPTION
	PINOUT A	PINOUT B	PINOUT C	PINOUT D		
CRST	3	3	—	—	I	Programmable reset timeout pin. Connect a capacitor between this pin and GND to program the reset timeout period. See <a href="#">Section 8.3.4</a> for more details.
CWD	2	2	—	—	I	Programmable watchdog timeout input. Watchdog timeout is set by connecting a capacitor between this pin and ground. See <a href="#">Section 8.3.2.1</a> for more details.
GND	4	4	4	4	—	Ground pin
MR	1	—	2	—	I	Manual reset pin. A logic low on this pin asserts the $\overline{\text{RESET}}$ . See <a href="#">Section 8.3.3</a> for more details.
$\overline{\text{RESET}}$	7	7	7	7	O	Reset output. Connect $\overline{\text{RESET}}$ to VDD using a pull up resistance when using open drain output. $\overline{\text{RESET}}$ is asserted when the voltage at the VDD pin goes below the undervoltage threshold ( $V_{\text{IT}}$ ) or MR pin is driven LOW. For pinout options which do not support independent WDO pin, $\overline{\text{RESET}}$ is also asserted for watchdog error. See <a href="#">Section 8.3.4</a> for more details.
SET0	5	1	1	1	I	Logic input. SET0, SET1, and WD-EN pins select the watchdog timer scaling and enable-disable the watchdog; see <a href="#">Section 8.3.2.4</a> for more details.
SET1	—	5	5	5	I	Logic input. SET0, SET1, and WD-EN pins select the watchdog timer scaling and enable-disable the watchdog; see <a href="#">Section 8.3.2.4</a> for more details.
VDD	8	8	8	8	I	Supply voltage pin. For noisy systems, connecting a 0.1- $\mu\text{F}$ bypass capacitor is recommended.
WD-EN	—	—	6	2	I	Logic input. Logic high input enables the watchdog monitoring feature. See <a href="#">Section 8.3.2.2</a> for more details.
WDI	6	6	3	3	I	Watchdog input. A falling transition (edge) must occur at this pin before the timeout expires in order for $\overline{\text{RESET}}$ / $\overline{\text{WDO}}$ to not assert. See <a href="#">Section 8.3.2</a> for more details.
$\overline{\text{WDO}}$	—	—	—	6	O	Watchdog output. Connect $\overline{\text{WDO}}$ to VDD using pull up resistance when using open drain output. $\overline{\text{WDO}}$ asserts when a watchdog error occurs. $\overline{\text{WDO}}$ only asserts when $\overline{\text{RESET}}$ is high. When a watchdog error occurs, $\overline{\text{WDO}}$ asserts for the set $\overline{\text{RESET}}$ timeout delay ( $t_D$ ). When $\overline{\text{RESET}}$ is asserted, $\overline{\text{WDO}}$ is deasserted and watchdog functionality is disabled. See <a href="#">Section 8.3.4</a> for more details.

## 7 Specifications

### 7.1 Absolute Maximum Ratings

over operating free-air temperature range, unless otherwise noted<sup>(1)</sup>

		MIN	MAX	UNIT
Voltage	VDD	-0.3	6.5	V
Voltage	C <sub>WD</sub> , C <sub>RST</sub> , WD-EN, SETx, WDI, MR <sup>(2)</sup> , RESET (Push Pull), WDO (Push Pull)	-0.3	V <sub>DD</sub> +0.3 <sup>(3)</sup>	V
	RESET (Open Drain), WDO (Open Drain)	-0.3	6.5	
Current	RESET, WDO pin	-20	20	mA
Temperature <sup>(4)</sup>	Operating ambient temperature, T <sub>A</sub>	-40	125	°C
Temperature	Storage, T <sub>stg</sub>	-65	150	

- (1) Stresses beyond those listed under *Absolute Maximum Rating* may cause permanent damage to the device. These are stress ratings only, which do not imply functional operation of the device at these or any other conditions beyond those indicated under *Recommended Operating Condition*. Exposure to absolute-maximum-rated conditions for extended periods may affect device reliability.
- (2) If the logic signal driving MR is less than V<sub>DD</sub>, then additional current flows into V<sub>DD</sub> and out of MR.
- (3) The absolute maximum rating is (V<sub>DD</sub> + 0.3) V or 6.5 V, whichever is smaller
- (4) As a result of the low dissipated power in this device, it is assumed that T<sub>J</sub> = T<sub>A</sub>.

### 7.2 ESD Ratings

			VALUE	UNIT
V <sub>(ESD)</sub>	Electrostatic discharge	Human body model (HBM), per AEC Q100-002 <sup>(1)</sup>	±2000	V
		Charged device model (CDM), per AEC Q100-011	±750	

- (1) AEC Q100-002 indicates that HBM stressing shall be in accordance with the ANSI/ESDA/JEDEC JS-001 specification.

### 7.3 Recommended Operating Conditions

over operating free-air temperature range (unless otherwise noted)

		MIN	NOM	MAX	UNIT
Voltage	VDD (Active Low output)	0.9		6	V
	C <sub>WD</sub> , C <sub>RST</sub> , WD-EN, SETx, WDI, MR <sup>(1)</sup>	0		VDD	
	RESET (Open Drain), WDO (Open Drain)	0		6	
	RESET (Open Drain), WDO (Push Pull)	0		VDD	
Current	RESET, WDO pin current	-5		5	mA
C <sub>RST</sub>	C <sub>RST</sub> pin capacitor range	1.5		1800	nF
C <sub>WD</sub>	C <sub>WD</sub> pin capacitor range	1.5		1000	nF
T <sub>A</sub>	Operating ambient temperature	-40		125	°C

- (1) If the logic signal driving MR is less than V<sub>DD</sub>, then additional current flows into V<sub>DD</sub> and out of MR. V<sub>MR</sub> should not be higher than V<sub>DD</sub>.

## 7.4 Thermal Information

THERMAL METRIC <sup>(1)</sup>		TPS35-Q1	UNIT
		DDF (SOT23-8)	
		8 PINS	
$R_{\theta JA}$	Junction-to-ambient thermal resistance	175.3	°C/W
$R_{\theta JC(top)}$	Junction-to-case (top) thermal resistance	94.7	°C/W
$R_{\theta JB}$	Junction-to-board thermal resistance	92.4	°C/W
$\Psi_{JT}$	Junction-to-top characterization parameter	8.4	°C/W
$\Psi_{JB}$	Junction-to-board characterization parameter	91.9	°C/W
$R_{\theta JC(bot)}$	Junction-to-case (bottom) thermal resistance	N/A	°C/W

- (1) For more information about traditional and new thermal metrics, see the [Semiconductor and IC Package Thermal Metrics](#) application report.

## 7.5 Electrical Characteristics

At  $1.04\text{ V} \leq V_{DD} \leq 6\text{ V}$ ,  $\overline{\text{MR}} = \text{Open}$ ,  $\overline{\text{RESET}}$  pull-up resistor ( $R_{\text{pull-up}}$ ) = 100 k $\Omega$  to VDD,  $\overline{\text{WDO}}$  pull-up resistor ( $R_{\text{pull-up}}$ ) = 100 k $\Omega$  to VDD, output load ( $C_{\text{LOAD}}$ ) = 10 pF and over operating free-air temperature range  $-40^{\circ}\text{C}$  to  $125^{\circ}\text{C}$ , unless otherwise noted. VDD ramp rate  $\leq 1\text{ V}/\mu\text{s}$ . Typical values are at  $T_A = 25^{\circ}\text{C}$

PARAMETER		TEST CONDITIONS		MIN	TYP	MAX	UNIT
<b>COMMON PARAMETERS</b>							
$V_{DD}$	Input supply voltage	Active LOW output		1.04		6	V
$V_{IT-}$	Negative-going input threshold accuracy (1)	$V_{IT-} = 1.05\text{ V to }1.95\text{ V}$		-1.4	$\pm 0.5$	1.4	%
		$V_{IT-} = 2.0\text{ V to }5.4\text{ V}$		-1.2	$\pm 0.5$	1.2	
$V_{HYS}$	Hysteresis $V_{IT-}$ pin	$V_{IT-} = 1.05\text{ V to }5.4\text{ V}$		3	5	7	%
$I_{DD}$	Supply current into VDD pin (2)	$V_{DD} = 2\text{ V}$ $V_{IT-} = 1.05\text{ V to }1.95\text{ V}$	$T_A = -40^{\circ}\text{C to }85^{\circ}\text{C}$		0.25	0.8	$\mu\text{A}$
					0.25	3	
		$V_{DD} = 6\text{ V}$ $V_{IT-} = 1.05\text{ V to }5.4\text{ V}$	$T_A = -40^{\circ}\text{C to }85^{\circ}\text{C}$		0.25	0.8	
					0.25	3	
$V_{IL}$	Low level input voltage $\overline{\text{WD-EN}}$ , $\overline{\text{WDI}}$ , $\overline{\text{SETX}}$ , $\overline{\text{MR}}$ (3)					$0.3V_{DD}$	V
$V_{IH}$	High level input voltage $\overline{\text{WD-EN}}$ , $\overline{\text{WDI}}$ , $\overline{\text{SETX}}$ , $\overline{\text{MR}}$ (3)			$0.7V_{DD}$			V
$R_{MR}$	Manual reset internal pull-up resistance				100		k $\Omega$
<b>RESET / WDO (Open-drain active-low)</b>							
$V_{OL}$	Low level output voltage	$V_{DD} = 1.5\text{ V}, 1.55\text{ V} \leq V_{IT-} \leq 3.35\text{ V}$ $I_{\text{OUT(Sink)}} = 500\text{ }\mu\text{A}$				300	mV
		$V_{DD} = 3.3\text{ V}, 3.4\text{ V} \leq V_{IT-} \leq 5.4\text{ V}$ $I_{\text{OUT(Sink)}} = 2\text{ mA}$				300	mV
$I_{\text{kg(OD)}}$	Open-Drain output leakage current	$V_{DD} = V_{\text{PULLUP}} = 6\text{ V}$ $T_A = -40^{\circ}\text{C to }85^{\circ}\text{C}$			10	30	nA
		$V_{DD} = V_{\text{PULLUP}} = 6\text{ V}$			10	120	nA
<b>RESET / WDO (Push-pull active-low)</b>							
$V_{POR}$	Power on $\overline{\text{RESET}}$ voltage (5)	$V_{\text{OL(max)}} = 300\text{ mV}$ $I_{\text{OUT(Sink)}} = 15\text{ }\mu\text{A}$				900	mV
$V_{OL}$	Low level output voltage	$V_{DD} = 0.9\text{ V}, 1.05\text{ V} \leq V_{IT-} \leq 1.5\text{ V}$ $I_{\text{OUT(Sink)}} = 15\text{ }\mu\text{A}$				300	mV
		$V_{DD} = 1.5\text{ V}, 1.55\text{ V} \leq V_{IT-} \leq 3.35\text{ V}$ $I_{\text{OUT(Sink)}} = 500\text{ }\mu\text{A}$				300	
		$V_{DD} = 3.3\text{ V}, 3.4\text{ V} \leq V_{IT-} \leq 5.4\text{ V}$ $I_{\text{OUT(Sink)}} = 2\text{ mA}$				300	
$V_{OH}$	High level output voltage	$V_{DD} = 1.8\text{ V}, 1.05\text{ V} \leq V_{IT-} \leq 1.4\text{ V}$ $I_{\text{OUT(Source)}} = 500\text{ }\mu\text{A}$		$0.8V_{DD}$			V
		$V_{DD} = 3.3\text{ V}, 1.45\text{ V} \leq V_{IT-} \leq 3.0\text{ V}$ $I_{\text{OUT(Source)}} = 500\text{ }\mu\text{A}$		$0.8V_{DD}$			
		$V_{DD} = 6\text{ V}, 3.05\text{ V} \leq V_{IT-} \leq 5.4\text{ V}$ $I_{\text{OUT(Source)}} = 2\text{ mA}$		$0.8V_{DD}$			

(1)  $V_{IT-}$  threshold voltage range from 1.05 V to 5.4 V in 50 mV steps.

(2) If the logic signal driving  $\overline{\text{MR}}$  is less than  $V_{DD}$ , then additional current flows into  $V_{DD}$  and out of  $\overline{\text{MR}}$ .

(3)  $V_{POR}$  is the minimum  $V_{DD}$  voltage level for a controlled output state

## 7.6 Timing Requirements

At  $1.04\text{ V} \leq V_{DD} \leq 6\text{ V}$ ,  $\overline{\text{MR}}$  = Open,  $\overline{\text{RESET}}$  pull-up resistor ( $R_{\text{pull-up}}$ ) = 100 k $\Omega$  to VDD,  $\overline{\text{WDO}}$  pull-up resistor ( $R_{\text{pull-up}}$ ) = 100 k $\Omega$  to VDD, output RESET / WDO load ( $C_{\text{LOAD}}$ ) = 10 pF and over operating free-air temperature range  $-40^{\circ}\text{C}$  to  $125^{\circ}\text{C}$ , unless otherwise noted. VDD ramp rate  $\leq 1\text{ V}/\mu\text{s}$ . Typical values are at  $T_A = 25^{\circ}\text{C}$

PARAMETER		TEST CONDITIONS	MIN	TYP	MAX	UNIT
$t_{\text{GL\_VIT-}}$	Glitch immunity $V_{\text{IT-}}$	5% $V_{\text{IT-}}$ overdrive <sup>(1)</sup>		15		$\mu\text{s}$
$t_{\text{MR\_PW}}$	$\overline{\text{MR}}$ pin pulse duration to assert reset			100		ns
$t_{\text{P-WD}}$	WDI pulse duration to start next frame <sup>(2)</sup>	$V_{DD} > V_{\text{IT-}}$	500			ns
$t_{\text{HD-WDEN}}$	WD-EN hold time to enable or disable WD operation <sup>(2)</sup>	$V_{DD} > V_{\text{IT-}}$	200			$\mu\text{s}$
$t_{\text{HD-SETx}}$	SETx hold time to change WD timer setting <sup>(2)</sup>	$V_{DD} > V_{\text{IT-}}$	150			$\mu\text{s}$
$t_{\text{WD}}$	Watchdog timeout period	Orderable Option TPS35xxxxB	0.8	1	1.2	ms
		Orderable Option TPS35xxxxC	4	5	6	
		Orderable Option TPS35xxxxD	9	10	11	
		Orderable Option TPS35xxxxE	18	20	22	
		Orderable Option TPS35xxxxF	45	50	55	
		Orderable Option TPS35xxxxG	90	100	110	
		Orderable Option TPS35xxxxH	180	200	220	
		Orderable Option TPS35xxxxI	0.9	1	1.1	s
		Orderable Option TPS35xxxxJ	1.26	1.4	1.54	
		Orderable Option TPS35xxxxK	1.44	1.6	1.76	
		Orderable Option TPS35xxxxL	9	10	11	
		Orderable Option TPS35xxxxM	45	50	55	
		Orderable Option TPS35xxxxN	90	100	110	

(1) Overdrive % =  $[(V_{DD}/V_{\text{IT-}}) - 1] \times 100\%$

(2) Not production tested

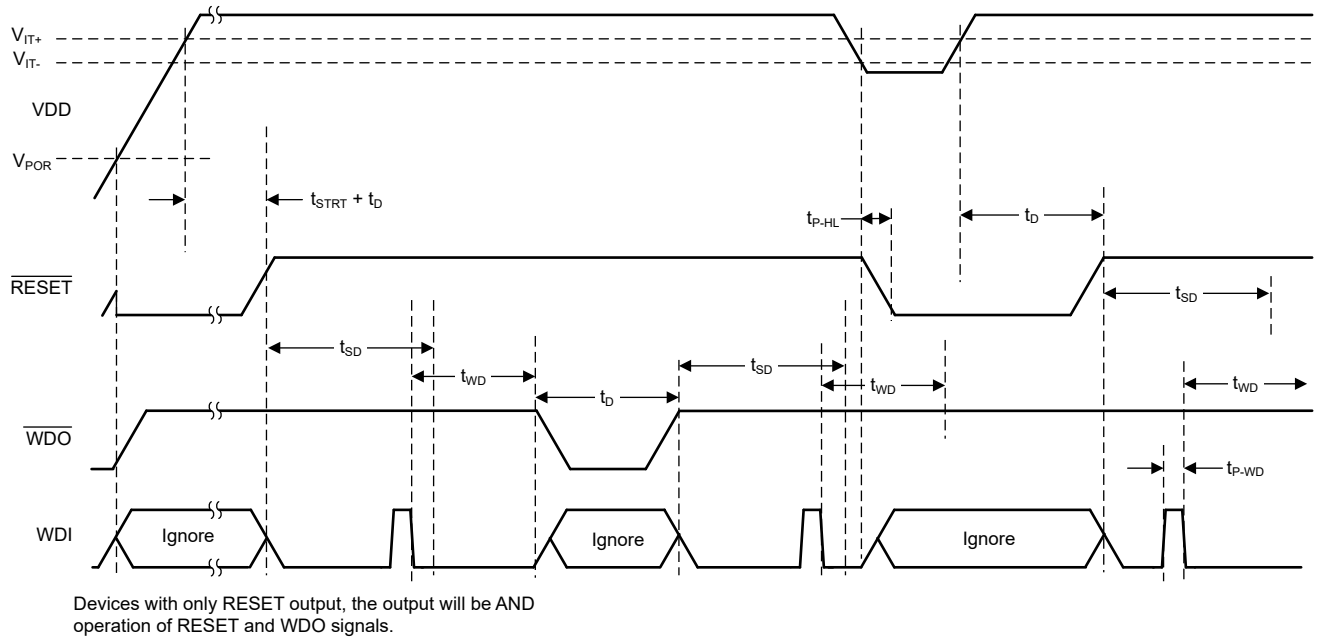
## 7.7 Switching Characteristics

At  $1.04\text{ V} \leq V_{DD} \leq 6\text{ V}$ ,  $\overline{MR} = \text{Open}$ ,  $\overline{RESET}$  pull-up resistor ( $R_{\text{pull-up}}$ ) = 100 k $\Omega$  to VDD,  $\overline{WDO}$  pull-up resistor ( $R_{\text{pull-up}}$ ) = 100 k $\Omega$  to VDD, output RESET / WDO load ( $C_{\text{LOAD}}$ ) = 10 pF and over operating free-air temperature range  $-40^{\circ}\text{C}$  to  $125^{\circ}\text{C}$ , unless otherwise noted. VDD ramp rate  $\leq 1\text{ V}/\mu\text{s}$ . Typical values are at  $T_A = 25^{\circ}\text{C}$

PARAMETER		TEST CONDITIONS	MIN	TYP	MAX	UNIT
$t_{\text{STRT}}$	Startup delay <sup>(4)</sup>				500	$\mu\text{s}$
$t_{\text{P\_HL}}$	RESET detect delay for VDD falling below $V_{\text{IT-}}$	$V_{DD} : (V_{\text{IT+}} + 10\%) \text{ to } (V_{\text{IT-}} - 10\%)$ (1)		30	50	$\mu\text{s}$
$t_{\text{SD}}$	Watchdog startup delay	Orderable part number TPS35xA, TPS35xG		0		ms
		Orderable part number TPS35xB, TPS35xH	180	200	220	
		Orderable part number TPS35xC, TPS35xI	450	500	550	
		Orderable part number TPS35xD, TPS35xJ	0.9	1	1.1	s
		Orderable part number TPS35xE, TPS35xK	4.5	5	5.5	
		Orderable part number TPS35xF, TPS35xL	9	10	11	
$t_{\text{D}}$	Reset time delay <sup>(3)</sup>	Orderable part number TPS35xxxxxB	1.6	2	2.4	ms
		Orderable part number TPS35xxxxxC	9	10	11	ms
		Orderable part number TPS35xxxxxD	22.5	25	27.5	ms
		Orderable part number TPS35xxxxxE	45	50	55	ms
		Orderable part number TPS35xxxxxF	90	100	110	ms
		Orderable part number TPS35xxxxxG	180	200	220	ms
		Orderable part number TPS35xxxxxH	0.9	1	1.1	s
		Orderable part number TPS35xxxxxI	9	10	11	s
$t_{\text{WDO}}$	Watchdog timeout delay			$t_{\text{D}}$		s
$t_{\text{MR\_RES}}$	Propagation delay from $\overline{MR}$ low to reset assertion	$V_{DD} \geq V_{\text{IT-}} + 0.2\text{ V}$ , $\overline{MR} = V_{\text{MR\_H}}$ to $V_{\text{MR\_L}}$		100		ns
$t_{\text{MR\_ID}}$	Delay from $\overline{MR}$ release to reset deassert	$V_{DD} = 3.3\text{ V}$ , $\overline{MR} = V_{\text{MR\_L}}$ to $V_{\text{MR\_H}}$		$t_{\text{D}}$		s

- (1)  $t_{\text{P\_HL}}$  measured from threshold trip point ( $V_{\text{IT-}}$ ) to RESET assert.  $V_{\text{IT+}} = V_{\text{IT-}} + V_{\text{HYS}}$   
(2) Specified by design parameter. When VDD starts from less than the specified minimum  $V_{DD}$  and then exceeds  $V_{\text{IT+}}$ , reset is deasserted after the startup delay ( $t_{\text{STRT}}$ ) +  $t_{\text{D}}$  delay.  
(3) VDD voltage transitions from ( $V_{\text{IT-}} - 10\%$ ) to ( $V_{\text{IT-}} + 10\%$ )

## 7.8 Timing Diagrams



**Figure 7-1. Functional Timing Diagram**

## 7.9 Typical Characteristics

all curves are taken at  $T_A = 25^\circ\text{C}$  (unless otherwise noted)

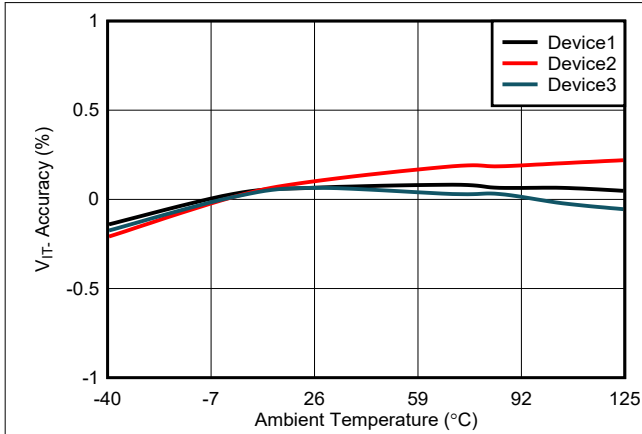


Figure 7-2.  $V_{IT}$  Accuracy vs Temperature

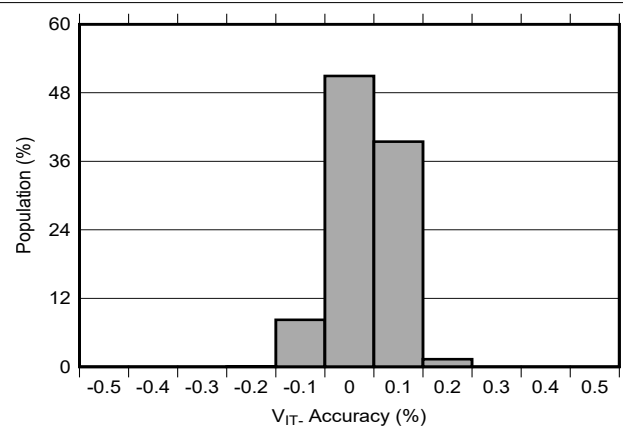


Figure 7-3.  $V_{IT}$  Accuracy Histogram

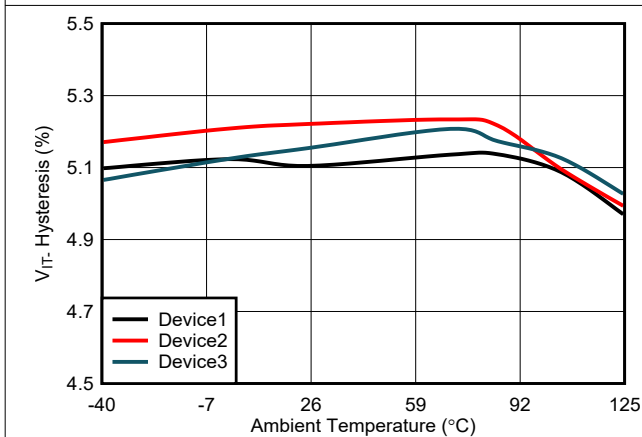


Figure 7-4.  $V_{IT}$  Hysteresis Vs Temperature

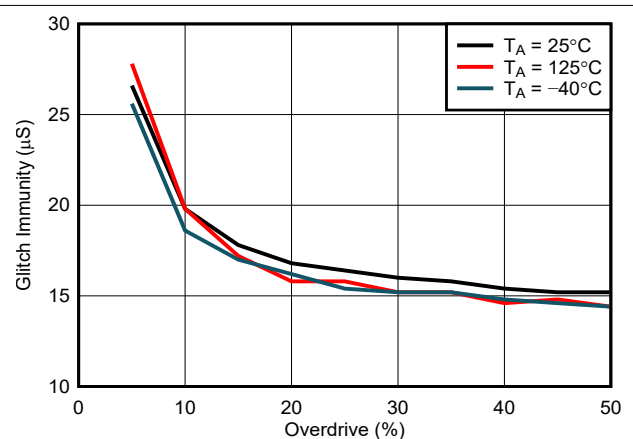


Figure 7-5. Supply Glitch Immunity vs Overdrive

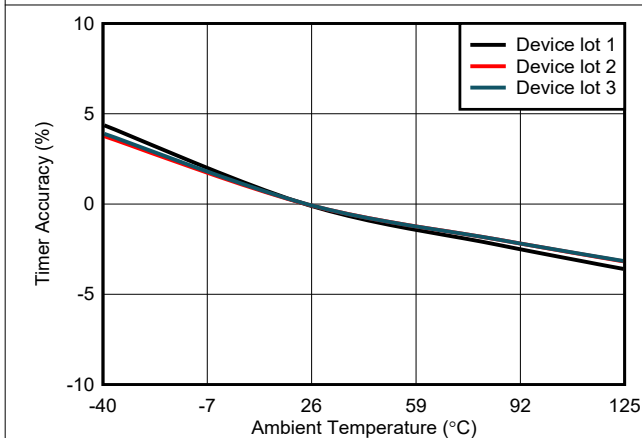


Figure 7-6. Timer Accuracy vs Temperature

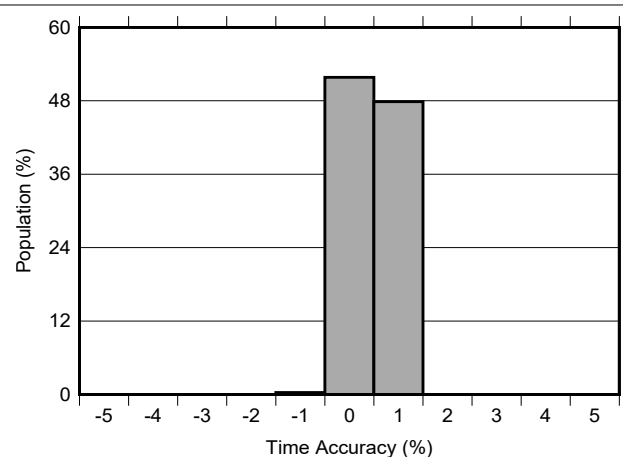
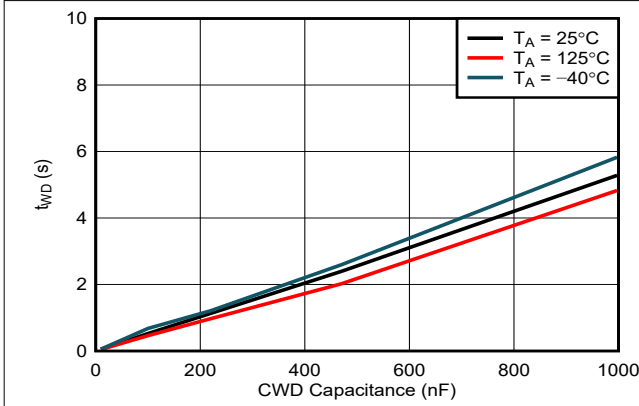


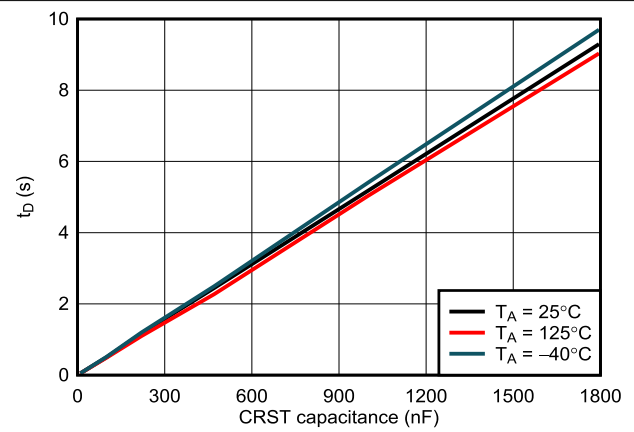
Figure 7-7. Timer Accuracy Histogram

### 7.9 Typical Characteristics (continued)

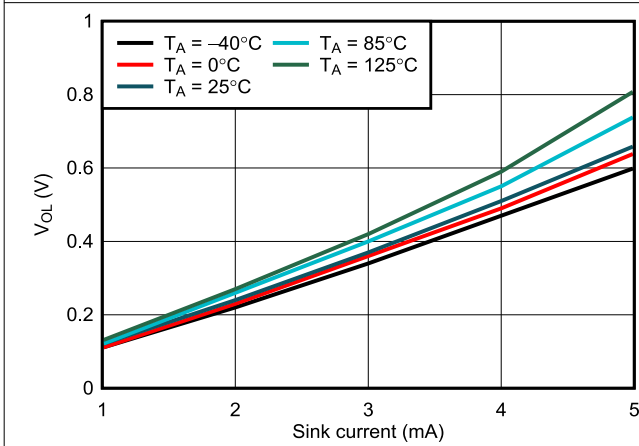
all curves are taken at  $T_A = 25^\circ\text{C}$  (unless otherwise noted)



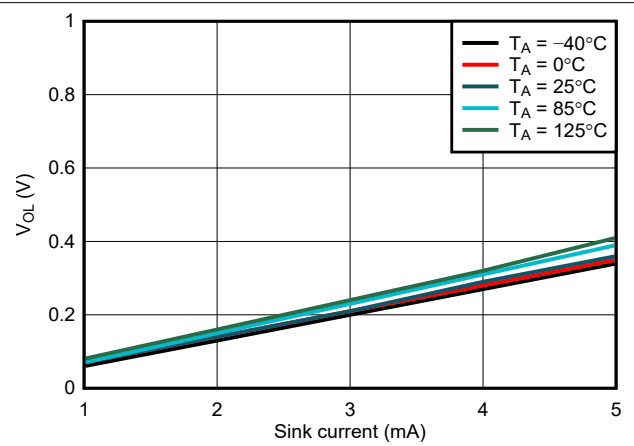
**Figure 7-8.  $t_{WD}$  vs Capacitance**



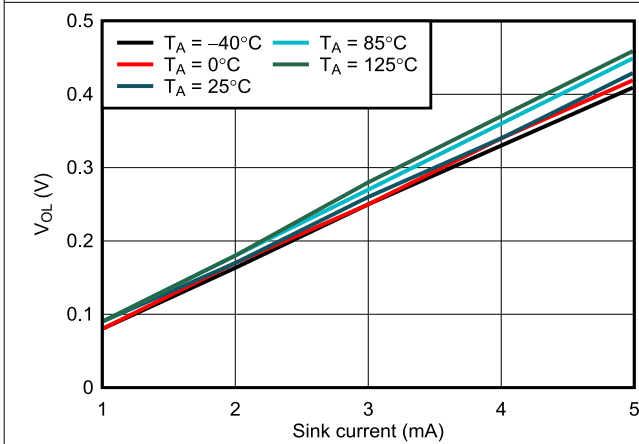
**Figure 7-9.  $t_D$  vs Capacitance**



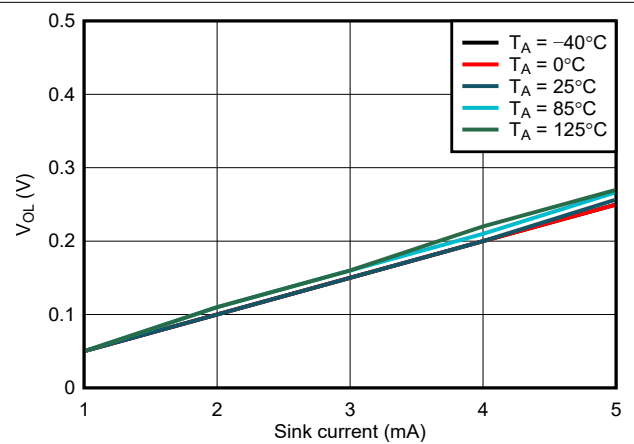
**Figure 7-10. RESET  $V_{OL}$  vs  $I_{sink}$ ,  $V_{DD} = 1.5\text{ V}$**



**Figure 7-11. WDO  $V_{OL}$  vs  $I_{sink}$ ,  $V_{DD} = 1.5\text{ V}$**



**Figure 7-12. RESET  $V_{OL}$  vs  $I_{sink}$ ,  $V_{DD} = 3.3\text{ V}$**



**Figure 7-13. WDO  $V_{OL}$  vs  $I_{sink}$ ,  $V_{DD} = 3.3\text{ V}$**

### 7.9 Typical Characteristics (continued)

all curves are taken at  $T_A = 25^\circ\text{C}$  (unless otherwise noted)

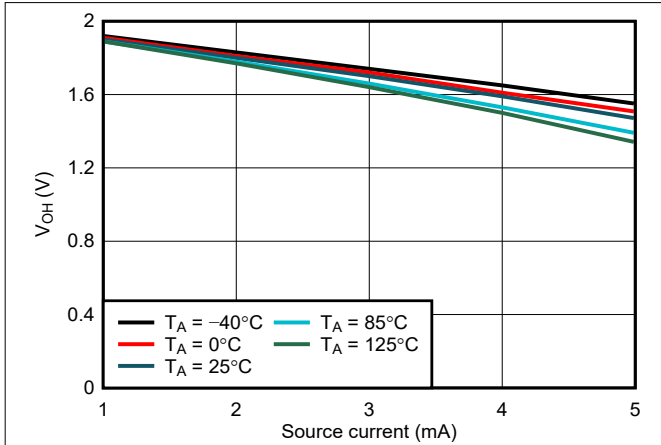


Figure 7-14. RESET  $V_{OH}$  vs  $I_{source}$ ,  $V_{DD} = 2.0\text{ V}$

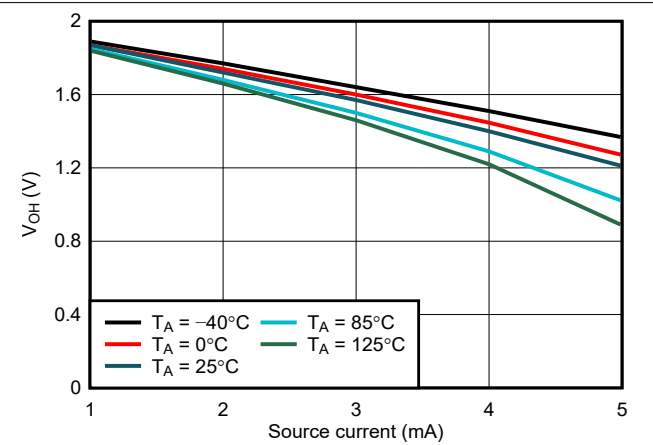


Figure 7-15. WDO  $V_{OH}$  vs  $I_{source}$ ,  $V_{DD} = 2.0\text{ V}$

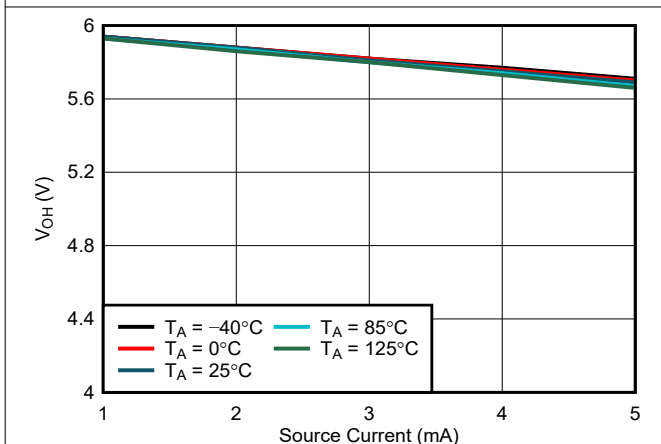


Figure 7-16. RESET  $V_{OH}$  vs  $I_{source}$ ,  $V_{DD} = 6.0\text{ V}$

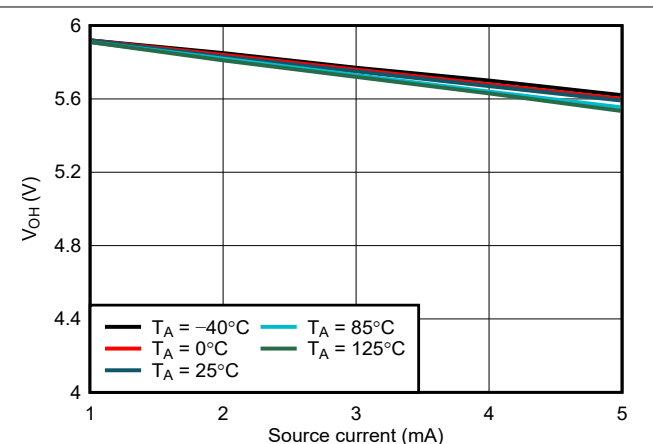


Figure 7-17. WDO  $V_{OH}$  vs  $I_{source}$ ,  $V_{DD} = 6.0\text{ V}$

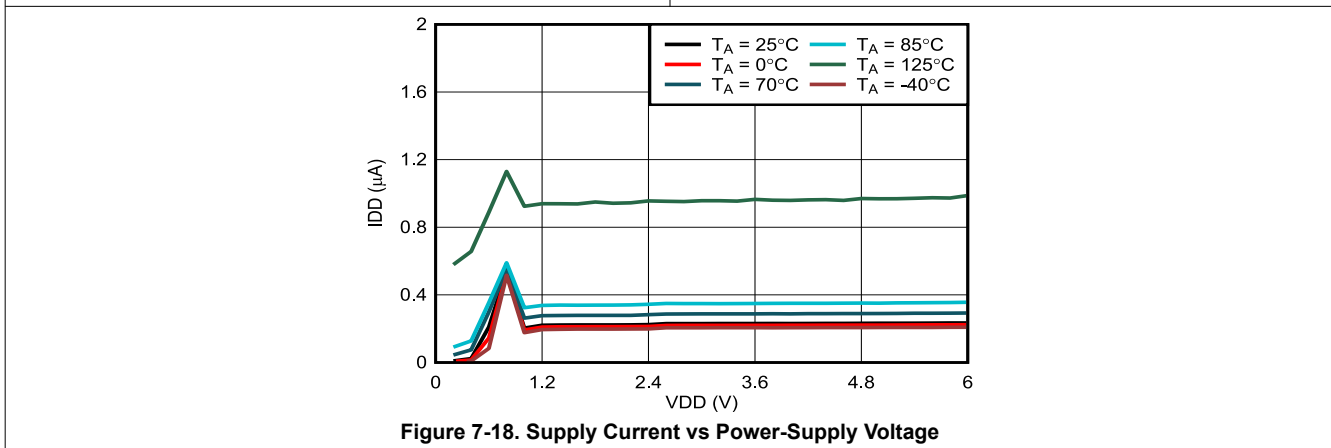


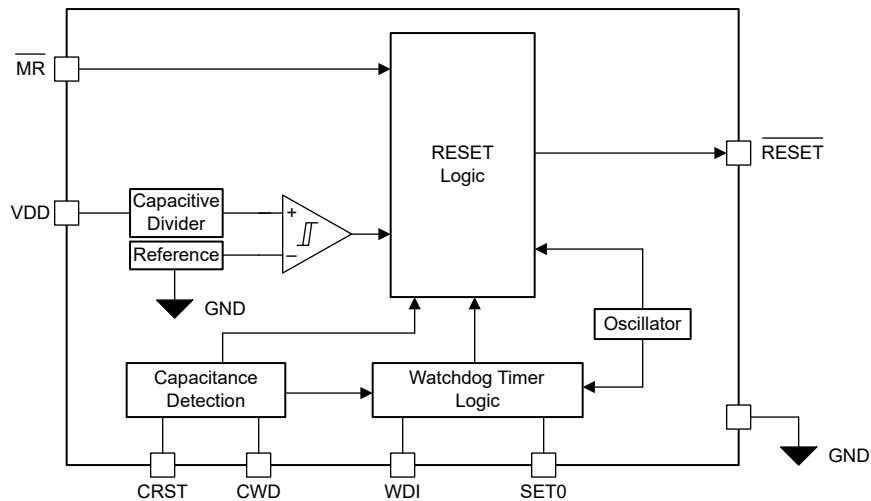
Figure 7-18. Supply Current vs Power-Supply Voltage

## 8 Detailed Description

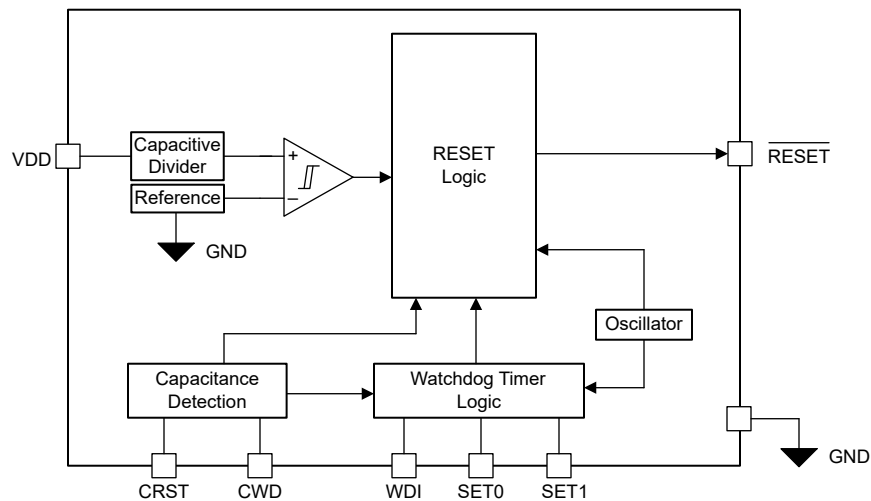
### 8.1 Overview

The TPS35-Q1 is a high-accuracy under voltage supervisor with an integrated timeout watchdog timer device. The device family supports multiple features related to watchdog operation in a compact 8 pin SOT23 package. The devices are available in 4 different pinout configurations. Each pinout offers access to different features to meet the various application requirements. The device family is rated for -Q100 applications.

### 8.2 Functional Block Diagrams



**Figure 8-1. Pinout Option A**



**Figure 8-2. Pinout Option B**

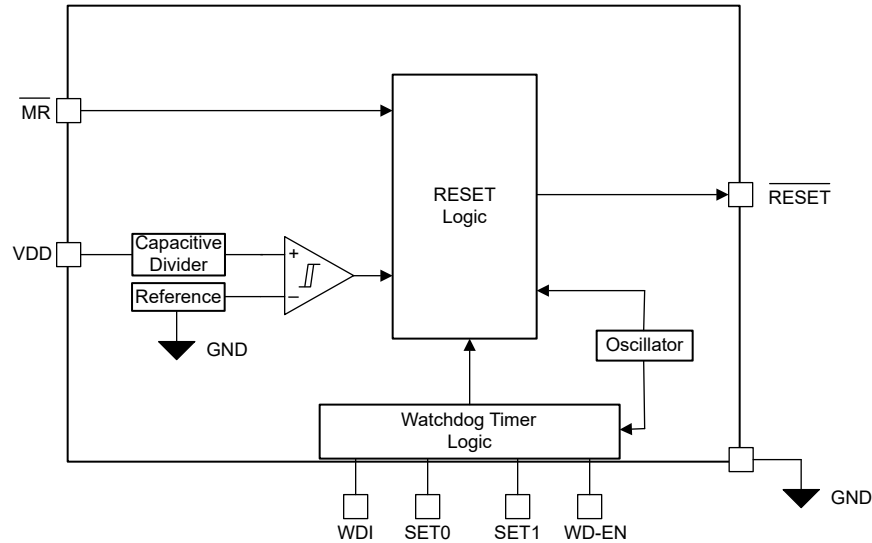


Figure 8-3. Pinout Option C

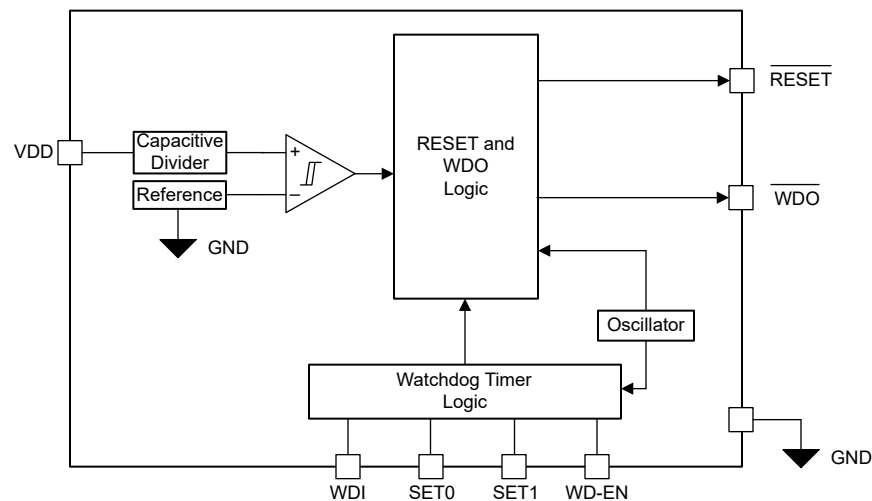


Figure 8-4. Pinout Option D

## 8.3 Feature Description

### 8.3.1 Voltage Supervisor

The TPS35-Q1 offers high accuracy under voltage supervisor function at very low quiescent current. The voltage supervisor function is always active. After the device powers up from  $V_{DD} < V_{POR}$ , the RESET and WDO outputs will be actively driven when  $V_{DD}$  is greater than  $V_{POR}$ . The device starts monitoring the supply level when the  $V_{DD}$  voltage is greater than 1.04 V. The device will hold the RESET pin asserted for  $t_{STRT} + t_D$  time after the  $V_{DD} > V_{IT+}$  ( $V_{IT-} + V_{HYS}$ ). Refer [Section 8.3.4](#) for the  $t_D$  value computation. For a capacitor based  $t_D$  delay option, the RESET will be asserted for  $t_{STRT} + 2$  msec time if the CRST pin is open.

Device pinout options A to C offer only RESET output. In these devices the internal RESET output from supervisor and WDO output from watchdog timer are ANDed together to drive the external RESET output.

The supervisor offers wide range of fixed monitoring thresholds ( $V_{IT-}$ ) from 1.05 V to 5.40 V in steps of 50 mV. The device asserts the RESET output when the  $V_{DD}$  signal falls below  $V_{IT-}$  threshold. The device offers hysteresis functionality for voltage supervision. This ensures the supply has recovered above the monitoring threshold before the RESET output is deasserted. The TPS35-Q1 typical voltage hysteresis ( $V_{HYS}$ ) is 5%. Along with the voltage hysteresis, the device keeps the RESET output asserted for time duration  $t_D$  after the supply has risen above  $V_{IT+}$ . The RESET output assert duration changes from  $t_D$  to  $t_{STRT} + t_D$  if the  $V_{DD}$  signal is ramping

from voltage  $< V_{POR}$ . The  $t_D$  time duration can be programmable using an external capacitor or fixed time options offered by the device.

The typical timing behavior for a voltage supervisor and the RESET output is showcased in Figure 8-5. The voltage supervisor monitoring output has higher priority over watchdog functionality. If the device voltage supervisor output is asserted, the watchdog functionality will be disabled including WDO assert control. The device resumes watchdog related functionality only after the supply is stable and the  $t_D$  time duration has elapsed.

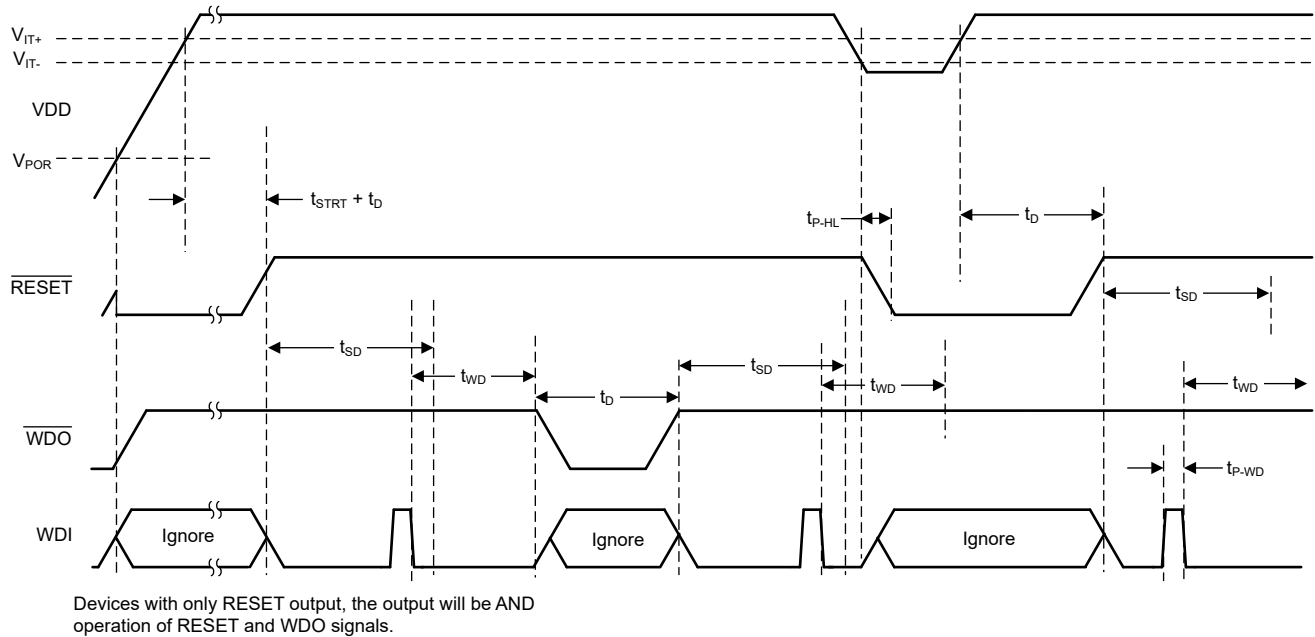


Figure 8-5. Voltage Supervisor Timing Diagram

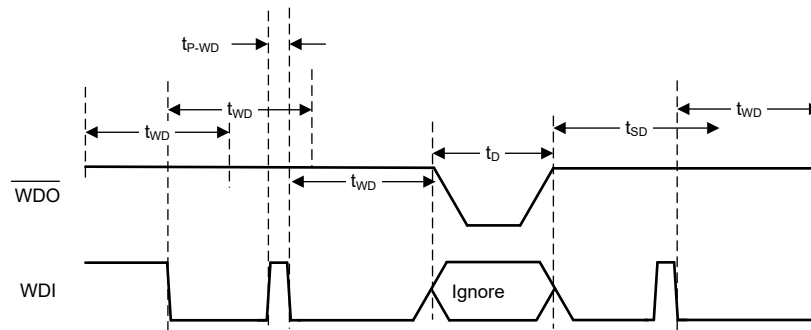
### 8.3.2 Timeout Watchdog Timer

The TPS35-Q1 offers high precision timeout watchdog timer monitoring. The device is available in multiple pinout options A to D which support multiple features to meet ever expanding needs of various applications. Ensure a correct pinout is selected to meet the application needs.

The timeout watchdog is active when the VDD voltage is higher than the  $V_{IT+} + V_{HYS}$  and the RESET is deasserted after the  $t_D$  time. The watchdog stays active as long as  $VDD > V_{IT-}$  and watchdog is enabled. TPS35-Q1 family offers various startup time delay options to ensure enough time is available for the host to complete boot operation. Please refer [Section 8.3.2.3](#) for additional details.

The timeout watchdog timer monitors the WDI pin for falling edge in the time frame defined by  $t_{WD}$  time period. Refer [Section 8.3.2.1](#) section to arrive at the relevant  $t_{WD}$  value needed for application. The timer value is reset when a valid falling edge is detected on WDI pin in the  $t_{WD}$  time duration. When a valid WDI transition is not detected in  $t_{WD}$  time, the device asserts RESET output for pinout options A, B and C or WDO output for pinout D. The RESET or WDO is asserted for time  $t_D$ . Refer [Section 8.3.4](#) to arrive at the relevant  $t_D$  value needed for application.

Figure 8-6 shows the basic operation for timeout watchdog timer operation. The TPS35-Q1 watchdog functionality supports multiple features. Details are available in following sub sections.



Devices with only RESET output, the RESET output will be asserted when watchdog error occurs.

**Figure 8-6. Timeout Watchdog Timer Operation**

### 8.3.2.1 $t_{WD}$ Timer

The  $t_{WD}$  timer for TPS35-Q1 can be set using an external capacitor connected between CWD pin and GND pin. This feature is available with pinout options A or B. Applications which are space constrained or need timer values which meet offered timer options, can benefit when using pinout options C or D. The TPS35-Q1 offers multiple fixed timer options ranging from 1 msec up-to 100 sec.

The TPS35-Q1, when using capacitance based timer, senses the capacitance value during the power up or after a RESET event. The capacitor is charged and discharged with known internal current source for one cycle to sense the capacitance value. The sensed value is used to arrive at  $t_{WD}$  timer for the watchdog operation. This unique implementation helps reduce the continuous charge and discharge current for the capacitor, thus reducing overall current consumption. Continuous charge and discharge of capacitance creates wider dead time (no watchdog monitor functionality) when capacitor is discharging. The dead time is higher for high value of capacitance. The unique implementation of TPS35-Q1 helps avoid the dead time as the capacitance is not continuously charging or discharging under normal operation. Ensure  $C_{CWD}$  is  $< 200 \times C_{CRST}$  for accurate calibration of capacitance. Equation 1 highlights the relationship between  $t_{WD}$  in second and CWD capacitance in farad. The  $t_{WD}$  timer is 20% accurate for an ideal capacitor. Accuracy of the capacitance will have additional impact on the  $t_{WD}$  time. Ensure the capacitance meets the recommended operating range. Capacitance outside the recommended range can lead to incorrect operation of the device.

$$t_{WD} \text{ (sec)} = 4.95 \times 10^6 \times C_{CWD} \text{ (F)} \quad (1)$$

The TPS35-Q1 also offers wide selection of high accuracy fixed timer options starting from 1 msec to 100 sec including various industry standard values. The TPS35-Q1 fixed time options are  $\pm 10\%$  accurate for  $t_{WD} \geq 10$  msec. For  $t_{WD} < 10$  msec, the accuracy is  $\pm 20\%$ .  $t_{WD}$  value relevant to application can be identified from the orderable part number. Refer Section 5 section to identify mapping of orderable part number to  $t_{WD}$  value.

The TPS35-Q1 offers flexibility to change the  $t_{WD}$  value on the fly by controlling the logic levels on the SETx pins. Section 8.3.2.4 section explains the advantages offered by this feature and the device behavior with various SETx pin combinations.

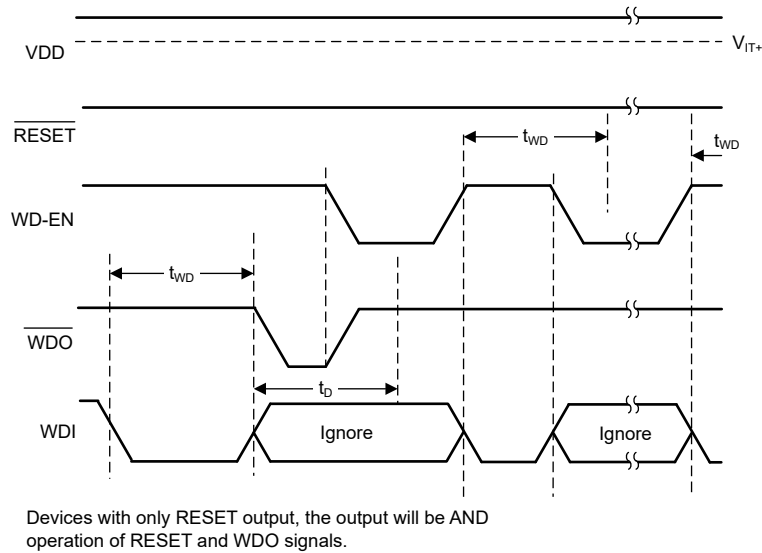
### 8.3.2.2 Watchdog Enable Disable Operation

The TPS35-Q1 supports watchdog enable or disable functionality. This functionality is critical for different use cases as listed below.

- Disable watchdog during firmware update to avoid host RESET.
- Disable watchdog during software step-by-step debug operation.
- Disable watchdog when performing critical task to avoid watchdog error interrupt.
- Keep watchdog disabled until host boots up.

The TPS35-Q1 supports watchdog enable or disable functionality through either WD-EN pin (pin configuration C) or SET[1:0] = 0b'01 (pin configuration B) logic combination. For a given pinout only one of these two methods is available for the user to disable watchdog operation.

For a pinout which offers a WD-EN pin, the watchdog enable disable functionality is controlled by the logic state of WD-EN pin. Drive WD-EN = 1 to enable the watchdog operation or drive WD-EN = 0 to disable the watchdog operation. The WD-EN pin can be toggled any time during the device operation. The Figure 8-7 diagram shows timing behavior with WD-EN pin control.



**Figure 8-7. Watchdog Enable: WD-EN Pin Control**

SET[1:0] = 0b'01 combination can be used to disable watchdog operation with a pinout which offers SET1 and SET0 pins, but does not include WD-EN pin. The SET pin logic states can be changed at any time during watchdog operation. Refer Section 8.3.2.4 section for additional details regarding SET[1:0] pin behavior.

Pinout options A, B offer watchdog timer control using a capacitance connected between CWD and GND pin. A capacitance value higher than recommended or connect to GND leads to watchdog functionality getting disabled. Capacitance based disable operation overrides the other two options mentioned above. Changing capacitance on the fly does not enable or disable watchdog operation. A power supply recycle or device recovery after UV fault,  $\overline{MR}$  low event is needed to detect change in capacitance.

Ongoing watchdog frame is terminated when watchdog is disabled. WDO stays deasserted when watchdog operation is disabled. For a pinout with only RESET output, the RESET can assert if supply supervisor error occurs. When enabled the device immediately enters  $t_{WD}$  frame and start watchdog monitoring operation.

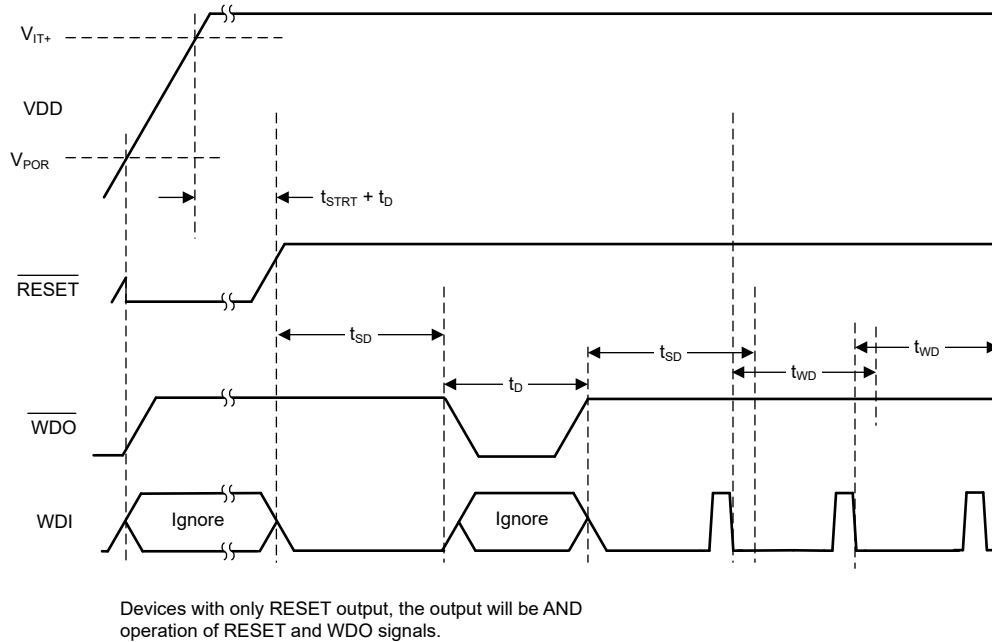
### 8.3.2.3 $t_{SD}$ Watchdog Start Up Delay

The TPS35-Q1 supports watchdog startup delay feature. This feature is activated after power up or after a RESET assert event or after WDO assert event. When  $t_{SD}$  frame is active, the device monitors the WDI pin but the WDO output is not asserted. This feature allows time for the host complete boot process before watchdog monitoring can take over. The start up delay helps avoid unexpected WDO or RESET assert events during boot. The  $t_{SD}$  time is predetermined based on the device part number selected. Refer Section 5 section for details to map the part number to  $t_{SD}$  time. Pinout option A, B are available only in no delay or 10 sec start up delay options.

The  $t_{SD}$  frame is complete when the time duration selected for  $t_{SD}$  is over or host provides a valid transition on the WDI pin. The host must provide a valid transition on the WDI pin during  $t_{SD}$  time. The device exits the  $t_{SD}$  frame and enters watchdog monitoring phase after valid WDI transition. Failure to provide valid transition on WDI pin triggers the watchdog error by asserting the WDO output pin. For devices with only RESET output, the RESET pin is asserted.

The  $t_{SD}$  frame is not initiated when the watchdog functionality is enabled using WD-EN pin or SET[1:0] pin combination as described in Section 8.3.2.2 section.

Figure 8-8 shows the operation for  $t_{SD}$  time frame.



**Figure 8-8.  $t_{SD}$  Frame Behavior**

### 8.3.2.4 SET Pin Behavior

The TPS35-Q1 offers one or two SET pins based on the pinout option selected. SET pins offer flexibility to the user to program the  $t_{WD}$  timer on the fly to meet various application requirements. Typical use cases where SET pin can be used are:

- Use wide timeout timer when host is in sleep mode, change to small timeout operation when host is operational. Watchdog can be used to wake up the host after long duration to perform the application related activities before going back to sleep.
- Change to wide timeout timer when performing system critical tasks to make sure the watchdog does not interrupt the critical task. Change timer to application specified interval after the critical task is complete.

The  $t_{WD}$  timer value for the device is combination of timer selection based on the CWD pin or fixed timer value along with SET pin logic level. The base  $t_{WD}$  timer value is decided based on the Watchdog Time selector in the [Section 5](#) section. The SET pin logic level is decoded during the device power up. The SET pin value can be changed any time during the operation. SETx pin change which leads to change of watchdog timer value or enable/disable state, terminates the ongoing watchdog frame immediately. SETx pins can be updated when WDO or RESET output is asserted as well. The updated  $t_{WD}$  timer value will be applied after output is deasserted and the  $t_{SD}$  timer is over or terminated.

For a pinout which offers only SET0 pin to the user, the  $t_{WD}$  multiplier value is decided based on the Watchdog Time Scaling selector in the [Section 5](#) section. [Table 8-1](#) showcases an example of the  $t_{WD}$  values for different SET0 logic levels when using Watchdog Time setting as option D = 10 msec.

**Table 8-1.  $t_{WD}$  Scaling with SET0 Pin Only (Pin Configuration A)**

WATCHDOG TIME SCALING SELECTION	$t_{WD}$	
	SET0 = 0	SET0 = 1
A	10 msec	20 msec
B	10 msec	40 msec
C	10 msec	80 msec
D	10 msec	160 msec
E	10 msec	320 msec
F	10 msec	640 msec

**Table 8-1.  $t_{WD}$  Scaling with SET0 Pin Only (Pin Configuration A) (continued)**

WATCHDOG TIME SCALING SELECTION	$t_{WD}$	
	SET0 = 0	SET0 = 1
G	10 msec	1280 msec

For pinouts which offer both SET0 & SET1 pins to the user, the  $t_{WD}$  multiplier value is decided based on the Watchdog Time Scaling selector in the [Section 5](#) section. Two SETx pins offer 3 different time scaling options. The SET[1:0] = 0b'01 combination disables the watchdog operation. [Table 8-2](#) showcases an example of the  $t_{WD}$  values for different SET[1:0] logic levels when using Watchdog Time setting as option G = 100 msec. The package pin out selected does not offer WD-EN pin.

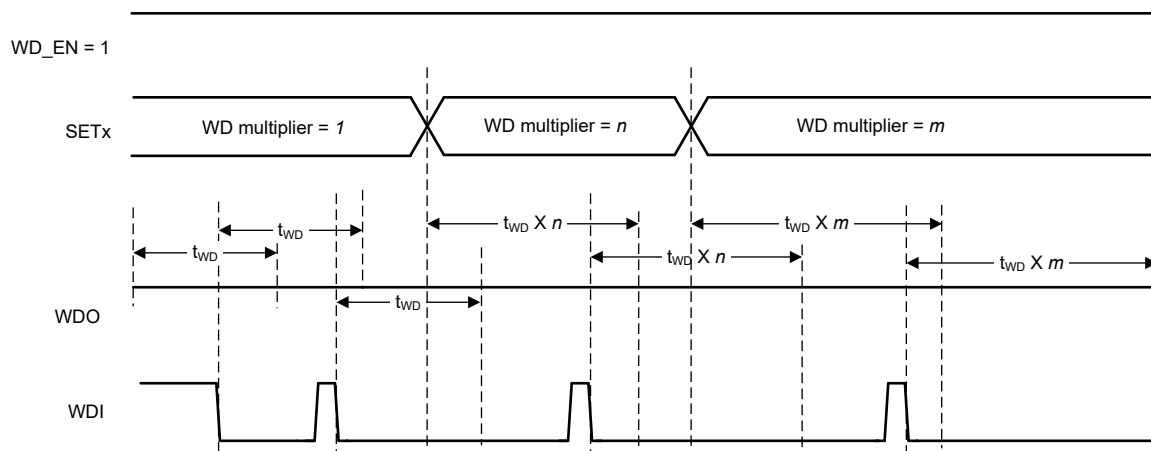
**Table 8-2.  $t_{WD}$  Scaling with SET0 & SET1 Pins, WD-EN Pin Not Available (Pin Configuration B)**

WATCHDOG TIME SCALING SELECTION	$t_{WD}$			
	SET[1:0] = 0b'00	SET[1:0] = 0b'01	SET[1:0] = 0b'10	SET[1:0] = 0b'11
A	100 msec	Watchdog disable	200 msec	400 msec
B	100 msec	Watchdog disable	400 msec	800 msec
C	100 msec	Watchdog disable	800 msec	1600 msec
D	100 msec	Watchdog disable	1600 msec	3200 msec
E	100 msec	Watchdog disable	3200 msec	6400 msec
F	100 msec	Watchdog disable	6400 msec	12800 msec
G	100 msec	Watchdog disable	12800 msec	25600 msec

Selected pinout option can offer WD-EN pin along with SET[1:0] pins (Pin Configuration C, D). With this pinout, the WD-EN pin controls watchdog enable and disable operation. The SET[1:0] = 0b'01 combination operates as SET[1:0] = 0b'00.

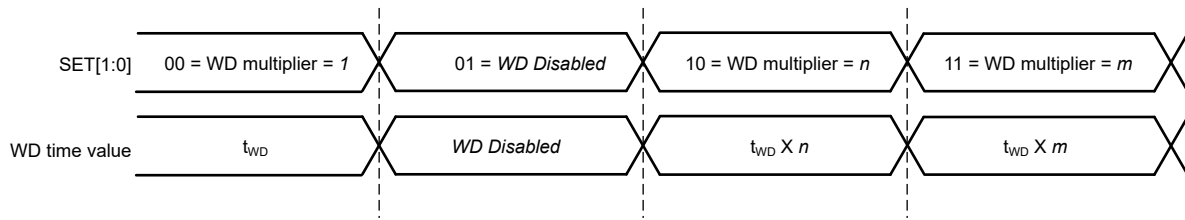
Make sure the  $t_{WD}$  value with SETx multiplier does not exceed 640 sec. If a selection of timer and multiplier results in  $t_{WD} > 640$  sec, the timer value will be restricted to 640 sec.

[Figure 8-9](#) to [Figure 8-11](#) diagrams show the timing behavior with respect to SETx status changes.

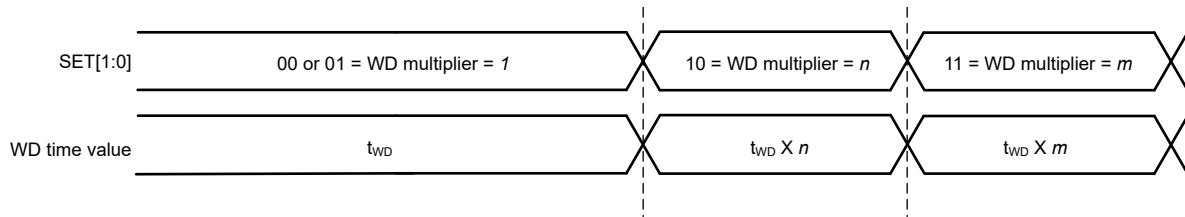


**Figure 8-9. Watchdog Behavior with SETx Pin Status**

SET Pin (2 Pins) Operation; WD\_EN pin Not available

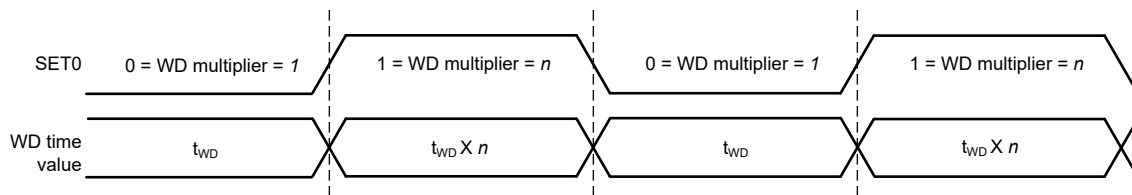


SET Pin (2 Pins) Operation; WD\_EN available = 1



$t_{WD}$  = Fixed based on OPN or programmable using capacitor  
 $n, m$  = Fixed based on timeset multiplier chosen

Figure 8-10. Watchdog Operation with 2 SET Pins



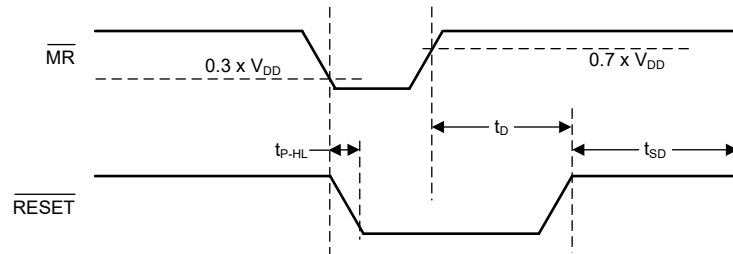
$t_{WD}$  = Fixed based on OPN or programmable using capacitor  
 $n$  = Fixed based on timeset multiplier chosen

Figure 8-11. Watchdog Operation with 1 SET Pin

### 8.3.3 Manual RESET

The TPS35-Q1 supports manual reset functionality using  $\overline{\text{MR}}$  pin.  $\overline{\text{MR}}$  pin when driven with voltage lower than  $0.3 \times V_{\text{DD}}$ , asserts the RESET output. The  $\overline{\text{MR}}$  pin has  $100 \text{ k}\Omega$  pull up to  $V_{\text{DD}}$ . The  $\overline{\text{MR}}$  pin can be left floating. The internal pull up makes sure the output is not asserted due to  $\overline{\text{MR}}$  pin trigger.

The output is deasserted after  $\overline{\text{MR}}$  pin voltage rises above  $0.7 \times V_{\text{DD}}$  voltage and time  $t_{\text{D}}$  is elapsed. Refer [Figure 8-12](#) for more details.



**Figure 8-12.  $\overline{\text{MR}}$  Pin Response**

### 8.3.4 RESET and WDO Output

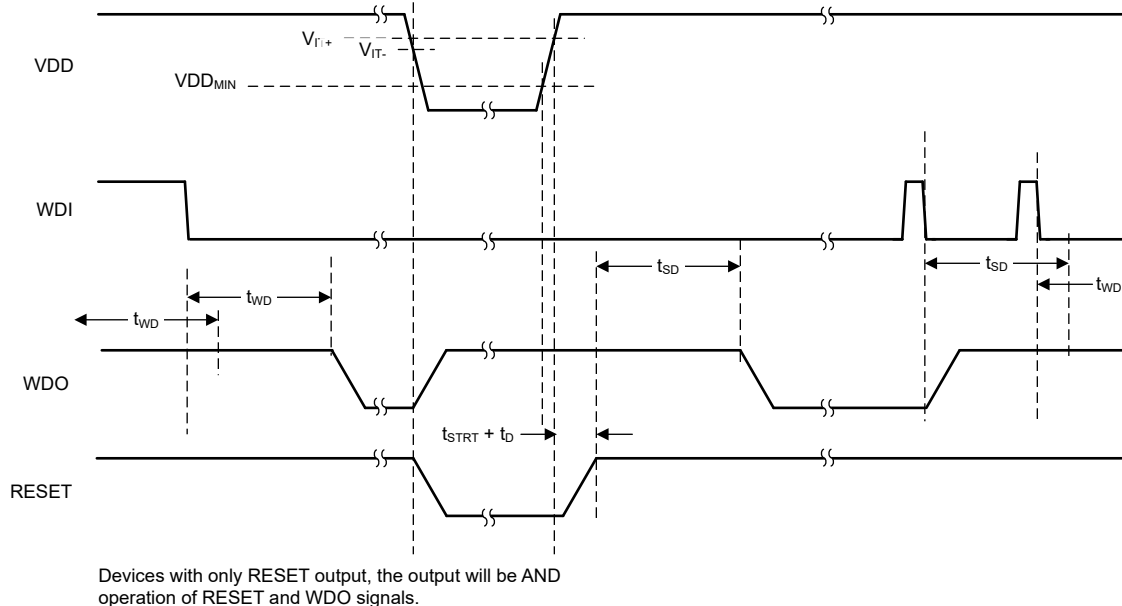
The TPS35-Q1 device can offer RESET or RESET with independent WDO output pin. The output configuration is dependent on the pinout variant selected. For a pinout which has only RESET output, the RESET output is asserted when VDD voltage is below the monitored threshold or  $\overline{\text{MR}}$  pin voltage is lower than threshold or watchdog timer error is detected. For a pinout which has independent RESET and WDO output pins, the RESET output is asserted when VDD voltage is below the monitored threshold or  $\overline{\text{MR}}$  pin voltage is lower than threshold. WDO output is asserted only when watchdog timer error is detected. RESET error has higher priority than WDO error. If RESET is asserted when WDO is asserted, the device deasserts the WDO pin and watchdog is disabled until RESET pin is deasserted and startup delay frame is terminated.

The output will be asserted for  $t_D$  time when any relevant events described above are detected. The time  $t_D$  can be programmed by connecting a capacitor between CRST pin and GND or device will assert  $t_D$  for fixed time duration as selected by orderable part number. Refer [Section 5](#) section for all available options.

[Equation 2](#) describes the relationship between capacitor value and the time  $t_D$ . Ensure the capacitance meets the recommended operating range. Capacitance outside the recommended range can lead to incorrect operation of the device.

$$t_D (\text{sec}) = 4.95 \times 10^6 \times C_{\text{CRST}} (\text{F}) \quad (2)$$

TPS35-Q1 also offers a unique option of latched output. An orderable with latched output will hold the output in asserted state indefinitely until the device is power cycled or the error condition is addressed. If the output is latched due to voltage supervisor undervoltage detection, the output latch will be released when VDD voltage rises above the  $V_{\text{IT}+} + V_{\text{HYS}}$  level. If the output is latched due to  $\overline{\text{MR}}$  pin low voltage, the output latch will be released when  $\overline{\text{MR}}$  pin voltage rises above  $0.7 \times V_{\text{DD}}$  level. If the output is latched due to watchdog timer error, the output latch will be released when a WDI negative edge is detected or the device is shutdown and powered up again. [Figure 8-13](#) shows timing behavior of the device with latched output configuration.



**Figure 8-13. Output Latch Timing Behavior**

## 8.4 Device Functional Modes

Table 8-3 summarizes the functional modes of the TPS35-Q1.

**Table 8-3. Device Functional Modes**

VDD	WATCHDOG STATUS	WDI	WDO	RESET
$V_{DD} < V_{POR}$	Not Applicable	—	Undefined	Undefined
$V_{POR} \leq V_{DD} < V_{IT-}$	Not Applicable	Ignored	High	Low
$V_{DD} \geq V_{IT+}$	Disabled	Ignored	High	High
	Enabled	$t_{pulse}^1 < t_{WD(min)}$	High	High
	Enabled	$t_{pulse}^1 > t_{WD(max)}$	Low	High

(1) Where  $t_{pulse}$  is the time between falling edges on WDI.

## 9 Application and Implementation

### Note

Information in the following applications sections is not part of the TI component specification, and TI does not warrant its accuracy or completeness. TI's customers are responsible for determining suitability of components for their purposes, as well as validating and testing their design implementation to confirm system functionality.

### 9.1 Application Information

The following sections describe in detail proper device implementation, depending on the final application requirements.

#### 9.1.1 CRST Delay

The TPS35-Q1 features two options for setting the reset delay ( $t_D$ ): using a fixed timing and programming the timing through an external capacitor.

##### 9.1.1.1 Factory-Programmed watchdog Timing

Fixed watchdog timings are available using pinout C and D. Using these timings enables a high-precision, 10% accurate watchdog timer  $t_{WD}$ .

##### 9.1.1.2 Adjustable Capacitor Timing

The TPS35-Q1 also offers programmable reset delay option when using pinout A and B. The TPS35-Q1 can be programmed to have a desired reset delay by connecting a capacitor between CRST pin and GND. The typical delay time resulting from a given external capacitance on the CRST pin can be calculated by [Equation 3](#), where  $t_D$  is the reset delay time in seconds and  $C_{CRST}$  is the capacitance in farads.

$$t_D (\text{sec}) = 4.95 \times 10^6 \times C_{CRST} (\text{F}) \quad (3)$$

To minimize the difference between the calculated reset delay time and the actual reset delay time, use a high-quality ceramic dielectric COG capacitor and minimize parasitic board capacitance around this pin. [Table 9-1](#) lists the reset delay time ideal capacitor values for  $C_{CRST}$ .

**Table 9-1. Reset Delay Time for Common Ideal Capacitor Values**

$C_{CRST}$	RESET DELAY TIME ( $t_D$ )			UNIT
	MIN <sup>(1)</sup>	TYP	MAX <sup>(1)</sup>	
10 nF	39.6	49.5	59.4	ms
100 nF	396	495	594	ms
1 $\mu$ F	3960	4950	5940	ms

(1) Minimum and maximum values are calculated using ideal capacitors.

#### 9.1.2 Watchdog Timer Functionality

The TPS35-Q1 features two options for setting the watchdog timer ( $t_{WD}$ ): using a fixed timing and programming the timing through an external capacitor.

##### 9.1.2.1 Factory-Programmed watchdog Timing

Fixed watchdog timings are available using pinout C and D. Using these timings enables a high-precision, 10% accurate watchdog timer  $t_{WD}$ .

##### 9.1.2.2 Adjustable Capacitor Timings

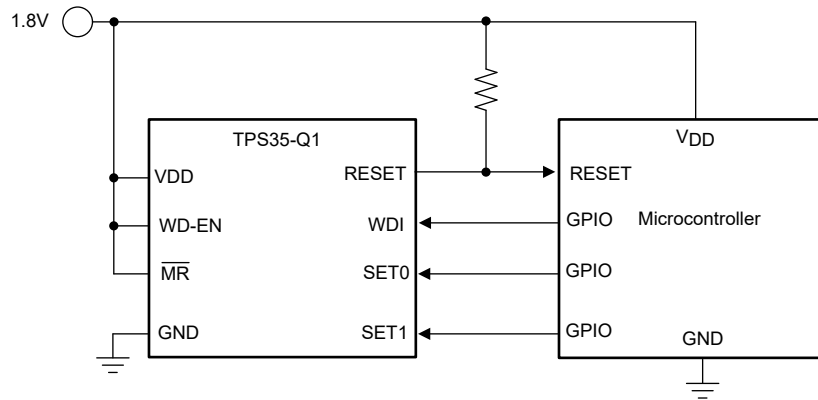
Adjustable  $t_{WD}$  timing is achievable by connecting a capacitor to the CWD pin. If this method is used, please consult [Equation 1](#) for calculating typical  $t_{WD}$  values using ideal capacitors. Capacitor tolerances cause the

actual device timing to vary such that the minimum of  $t_{WD}$  can decrease and the maximum of  $t_{WD}$  can increase by the capacitor tolerance. For the most accurate timing, use ceramic capacitors with COG dielectric material.

## 9.2 Typical Applications

### 9.2.1 Design 1: Monitoring a Microcontroller Supply Voltage and Watchdog Timer

The TPS35-Q1 features high-accuracy (1.2% maximum) voltage supervising along with on-the-fly adjustable watchdog timing in order to monitor critical processing elements in systems.



Copyright © 2023, Texas Instruments Incorporated

**Figure 9-1. Microcontroller Supply and Watchdog Monitoring Circuit**

#### 9.2.1.1 Design Requirements

**Table 9-2. Design Parameters**

PARAMETER	DESIRED REQUIREMENT	DESIGN RESULT
Threshold Voltage	Typical threshold voltage of 1.65 V	Typical threshold voltage of 1.65 V
Watchdog Timeout Period	Typical timeout period of 1.6 s	Typical timeout period of 1.6 s
RESET Delay	Typical reset delay of 200 ms	Typical reset delay of 200 ms
Startup Delay	Minimum startup delay of 700 ms	Minimum startup delay of 900 ms
Output Logic	Open-drain	Open-drain
Maximum Device Current Consumption	20 $\mu$ A	250 nA typical, 3 $\mu$ A maximum

#### 9.2.1.2 Detailed Design Procedure

##### 9.2.1.2.1 Setting the Voltage Threshold

The negative-going threshold voltage,  $V_{IT-}$ , is set by the device variant. Equation 4 shows how to calculate the "Threshold Voltage" section of the orderable part number.

$$\text{OPN "Threshold Voltage" number} = (V_{IT-} - 1) / 0.05 \quad (4)$$

In this example, the nominal supply voltage for the microcontroller is 1.8 V. The minimum supply voltage is 10% lower than the nominal supply voltage, or 1.62 V. Setting a 1.65 V threshold ensures that the device will be reset just before the supply voltage reaches the minimum allowed. Thus a 1.65 V threshold is chosen and, using Equation 4, the part number is reduced to TPS35xx13xxxxxxQ1. Since the hysteresis is 5% typical, the positive-going threshold voltage,  $V_{IT+}$ , is 1.73 V.

##### 9.2.1.2.2 Meeting the Watchdog Timeout Period

The watchdog timeout design requirement can be met either by using a fixed-timeout version of the TPS35-Q1 or by connecting a capacitor between the CWD pin and GND. The typical values can be met with

preprogrammed fixed time options, hence a pinout offering fixed time options is selected. Please see the [Timing Requirements](#) for a list of fixed timeouts. If using the CWD feature, pinout A or B must be used; please refer to [t<sub>WD</sub> Timer](#) for instructions on how to program the timeout period. The design requirement in this example is  $t_{WD} = 1.6$  s. This is one of the fixed timeout options offered by pinout C or D. Thus the possible variant option is narrowed down to TPS35Cx13KAxDDFRQ1.

#### 9.2.1.2.3 Setting the Reset Delay

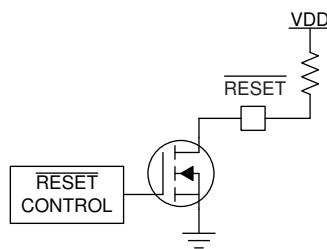
The reset delay requirement can be met either by using a fixed-timeout version of the TPS35-Q1 or by connecting a capacitor between the CRST pin and GND. The typical values can be met with preprogrammed fixed time options, hence a pinout offering fixed time options is selected. Please see the [Timing Requirements](#) for a list of fixed timeouts. If using the CRST feature, pinout A or B must be used; please refer to the [Timing Specifications](#) for instructions on how to program the timeout period. The design requirement in this example is  $t_D = 200$  ms. Thus the possible variant option is narrowed down to TPS35Cx13KAGDDFRQ1.

#### 9.2.1.2.4 Setting the Startup Delay and Output Topology

The startup delay and output topology are set by the device variant. Please refer to [Device Comparison](#) for the possible options. A minimum startup delay of 700 ms and open-drain output are desired, thus Option D, 1 s typical startup delay and open-drain active-low, is selected. Thus the option suitable to meet design requirements is TPS35CD13KAGDDFRQ1.

#### 9.2.1.2.5 Calculating the RESET Pullup Resistor

The TPS35-Q1 uses an open-drain configuration for the  $\overline{\text{RESET}}$  output, as shown in [Figure 9-2](#). When the FET is off, the resistor pulls the drain of the transistor to VDD and when the FET is turned on, the FET pulls the output to ground, thus creating an effective resistor divider. The resistors in this divider must be chosen to ensure that  $V_{OL}$  is below its maximum value. To choose the proper pullup resistor, there are three key specifications to keep in mind: the pullup voltage ( $V_{PU}$ ), the recommended maximum  $\overline{\text{RESET}}$  pin current ( $I_{RST}$ ), and  $V_{OL}$ . The maximum  $V_{OL}$  is 0.3 V, meaning that the effective resistor divider created must be able to bring the voltage on the reset pin below 0.3 V with  $I_{RST}$  kept below 2 mA for  $V_{DD} \geq 3$  V and 500  $\mu\text{A}$  for  $V_{DD} = 1.5$  V. For this example, with a  $V_{PU} = V_{DD} = 1.5$  V, a resistor must be chosen to keep  $I_{RST}$  below 500  $\mu\text{A}$  because this value is the maximum consumption current allowed. To ensure this specification is met, a pullup resistor value of 10 k $\Omega$  was selected, which sinks a maximum of 180  $\mu\text{A}$  when  $\overline{\text{RESET}}$  is asserted.



**Figure 9-2. Open-Drain  $\overline{\text{RESET}}$  Configuration**

## 10 Power Supply Recommendations

This device is designed to operate from an input supply with a voltage range between 1.04 V and 6 V. An input supply capacitor is not required for this device; however, if the input supply is noisy, then good analog practice is to place a 0.1- $\mu\text{F}$  capacitor between the VDD pin and the GND pin.

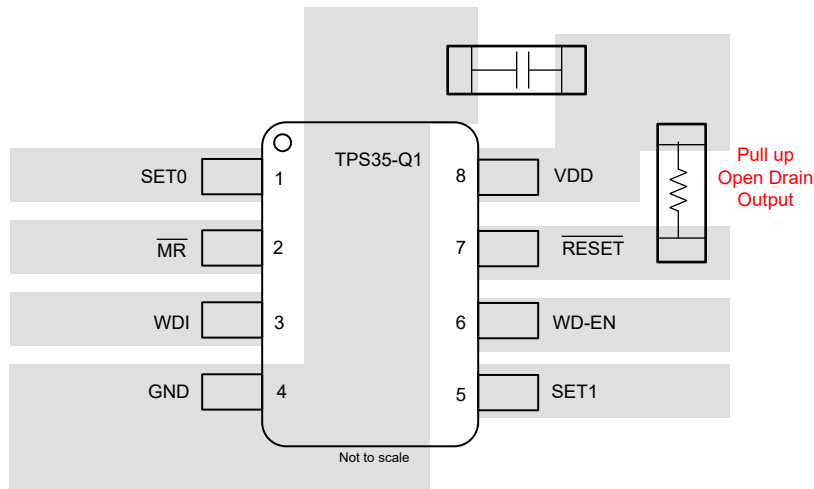
## 11 Layout

### 11.1 Layout Guidelines

Make sure that the connection to the VDD pin is low impedance. Good analog design practice recommends placing a 0.1- $\mu$ F ceramic capacitor as near as possible to the VDD pin. If a capacitor is not connected to the CRST pin, then minimize parasitic capacitance on this pin so the  $\overline{\text{RESET}}$  delay time is not adversely affected.

- Make sure that the connection to the VDD pin is low impedance. Good analog design practice is to place a 0.1- $\mu$ F ceramic capacitor as near as possible to the VDD pin.
- Place  $C_{\text{CRST}}$  capacitor as close as possible to the CRST pin.
- Place  $C_{\text{CWD}}$  capacitor as close as possible to the CWD pin.
- Place the pullup resistor on the  $\overline{\text{RESET}}$  pin as close to the pin as possible.

### 11.2 Layout Example



Copyright © 2023, Texas Instruments Incorporated

**Figure 11-1. Typical Layout for the Pinout C of TPS35-Q1**

## 12 Device and Documentation Support

### 12.1 Receiving Notification of Documentation Updates

To receive notification of documentation updates, navigate to the device product folder on [ti.com](http://ti.com). Click on *Subscribe to updates* to register and receive a weekly digest of any product information that has changed. For change details, review the revision history included in any revised document.

### 12.2 Support Resources

TI E2E™ [support forums](#) are an engineer's go-to source for fast, verified answers and design help — straight from the experts. Search existing answers or ask your own question to get the quick design help you need.

Linked content is provided "AS IS" by the respective contributors. They do not constitute TI specifications and do not necessarily reflect TI's views; see TI's [Terms of Use](#).

### 12.3 Trademarks

TI E2E™ is a trademark of Texas Instruments.  
All trademarks are the property of their respective owners.

### 12.4 Electrostatic Discharge Caution



This integrated circuit can be damaged by ESD. Texas Instruments recommends that all integrated circuits be handled with appropriate precautions. Failure to observe proper handling and installation procedures can cause damage.

ESD damage can range from subtle performance degradation to complete device failure. Precision integrated circuits may be more susceptible to damage because very small parametric changes could cause the device not to meet its published specifications.

### 12.5 Glossary

[TI Glossary](#) This glossary lists and explains terms, acronyms, and definitions.

### 13 Mechanical, Packaging, and Orderable Information

The following pages include mechanical, packaging, and orderable information. This information is the most current data available for the designated devices. This data is subject to change without notice and revision of this document. For browser-based versions of this data sheet, refer to the left-hand navigation.

**PACKAGING INFORMATION**

Orderable Device	Status (1)	Package Type	Package Drawing	Pins	Package Qty	Eco Plan (2)	Lead finish/ Ball material (6)	MSL Peak Temp (3)	Op Temp (°C)	Device Marking (4/5)	Samples
TPS35AA38AGADDFRQ1	ACTIVE	SOT-23-THIN	DDF	8	3000	RoHS & Green	NIPDAU	Level-1-260C-UNLIM	-40 to 125	NLHOE	<a href="#">Samples</a>
TPS35CA43DACDDFRQ1	ACTIVE	SOT-23-THIN	DDF	8	3000	RoHS & Green	NIPDAU	Level-1-260C-UNLIM	-40 to 125	NLHOC	<a href="#">Samples</a>

(1) The marketing status values are defined as follows:

**ACTIVE:** Product device recommended for new designs.

**LIFEBUY:** TI has announced that the device will be discontinued, and a lifetime-buy period is in effect.

**NRND:** Not recommended for new designs. Device is in production to support existing customers, but TI does not recommend using this part in a new design.

**PREVIEW:** Device has been announced but is not in production. Samples may or may not be available.

**OBSOLETE:** TI has discontinued the production of the device.

(2) **RoHS:** TI defines "RoHS" to mean semiconductor products that are compliant with the current EU RoHS requirements for all 10 RoHS substances, including the requirement that RoHS substance do not exceed 0.1% by weight in homogeneous materials. Where designed to be soldered at high temperatures, "RoHS" products are suitable for use in specified lead-free processes. TI may reference these types of products as "Pb-Free".

**RoHS Exempt:** TI defines "RoHS Exempt" to mean products that contain lead but are compliant with EU RoHS pursuant to a specific EU RoHS exemption.

**Green:** TI defines "Green" to mean the content of Chlorine (Cl) and Bromine (Br) based flame retardants meet JS709B low halogen requirements of <=1000ppm threshold. Antimony trioxide based flame retardants must also meet the <=1000ppm threshold requirement.

(3) MSL, Peak Temp. - The Moisture Sensitivity Level rating according to the JEDEC industry standard classifications, and peak solder temperature.

(4) There may be additional marking, which relates to the logo, the lot trace code information, or the environmental category on the device.

(5) Multiple Device Markings will be inside parentheses. Only one Device Marking contained in parentheses and separated by a "~" will appear on a device. If a line is indented then it is a continuation of the previous line and the two combined represent the entire Device Marking for that device.

(6) Lead finish/Ball material - Orderable Devices may have multiple material finish options. Finish options are separated by a vertical ruled line. Lead finish/Ball material values may wrap to two lines if the finish value exceeds the maximum column width.

**Important Information and Disclaimer:**The information provided on this page represents TI's knowledge and belief as of the date that it is provided. TI bases its knowledge and belief on information provided by third parties, and makes no representation or warranty as to the accuracy of such information. Efforts are underway to better integrate information from third parties. TI has taken and continues to take reasonable steps to provide representative and accurate information but may not have conducted destructive testing or chemical analysis on incoming materials and chemicals. TI and TI suppliers consider certain information to be proprietary, and thus CAS numbers and other limited information may not be available for release.

In no event shall TI's liability arising out of such information exceed the total purchase price of the TI part(s) at issue in this document sold by TI to Customer on an annual basis.

**OTHER QUALIFIED VERSIONS OF TPS35-Q1 :**

- Catalog : [TPS35](#)

## NOTE: Qualified Version Definitions:

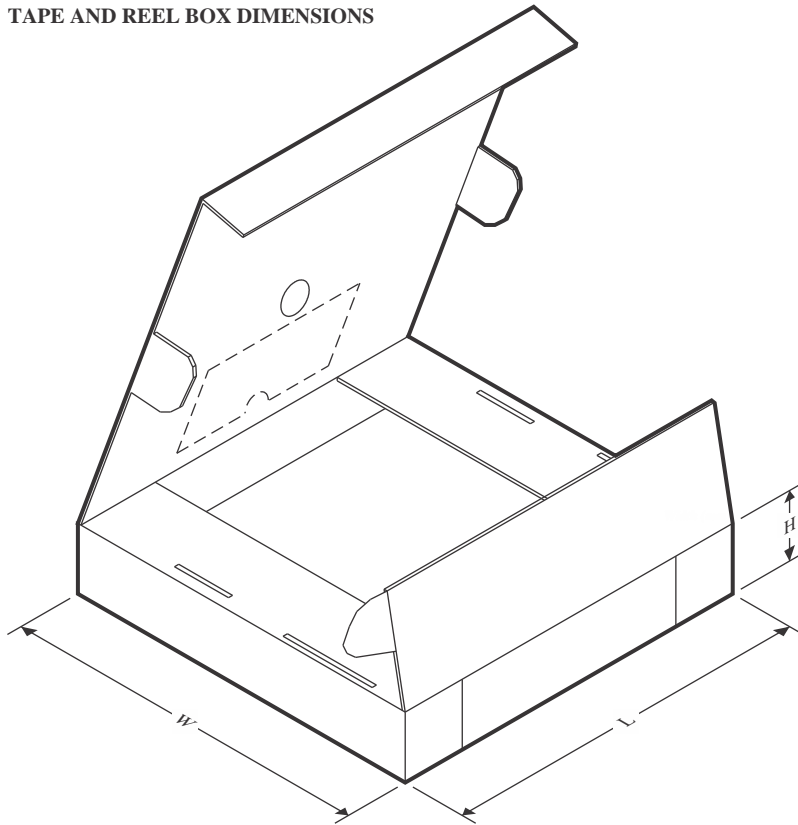
- Catalog - TI's standard catalog product

**TAPE AND REEL INFORMATION**

**QUADRANT ASSIGNMENTS FOR PIN 1 ORIENTATION IN TAPE**


\*All dimensions are nominal

Device	Package Type	Package Drawing	Pins	SPQ	Reel Diameter (mm)	Reel Width W1 (mm)	A0 (mm)	B0 (mm)	K0 (mm)	P1 (mm)	W (mm)	Pin1 Quadrant
TPS35AA38AGADDFRQ1	SOT-23-THIN	DDF	8	3000	180.0	8.4	3.2	3.2	1.4	4.0	8.0	Q3
TPS35CA43DACDDFRQ1	SOT-23-THIN	DDF	8	3000	180.0	8.4	3.2	3.2	1.4	4.0	8.0	Q3

**TAPE AND REEL BOX DIMENSIONS**


\*All dimensions are nominal

Device	Package Type	Package Drawing	Pins	SPQ	Length (mm)	Width (mm)	Height (mm)
TPS35AA38AGADDFRQ1	SOT-23-THIN	DDF	8	3000	210.0	185.0	35.0
TPS35CA43DACDDFRQ1	SOT-23-THIN	DDF	8	3000	210.0	185.0	35.0

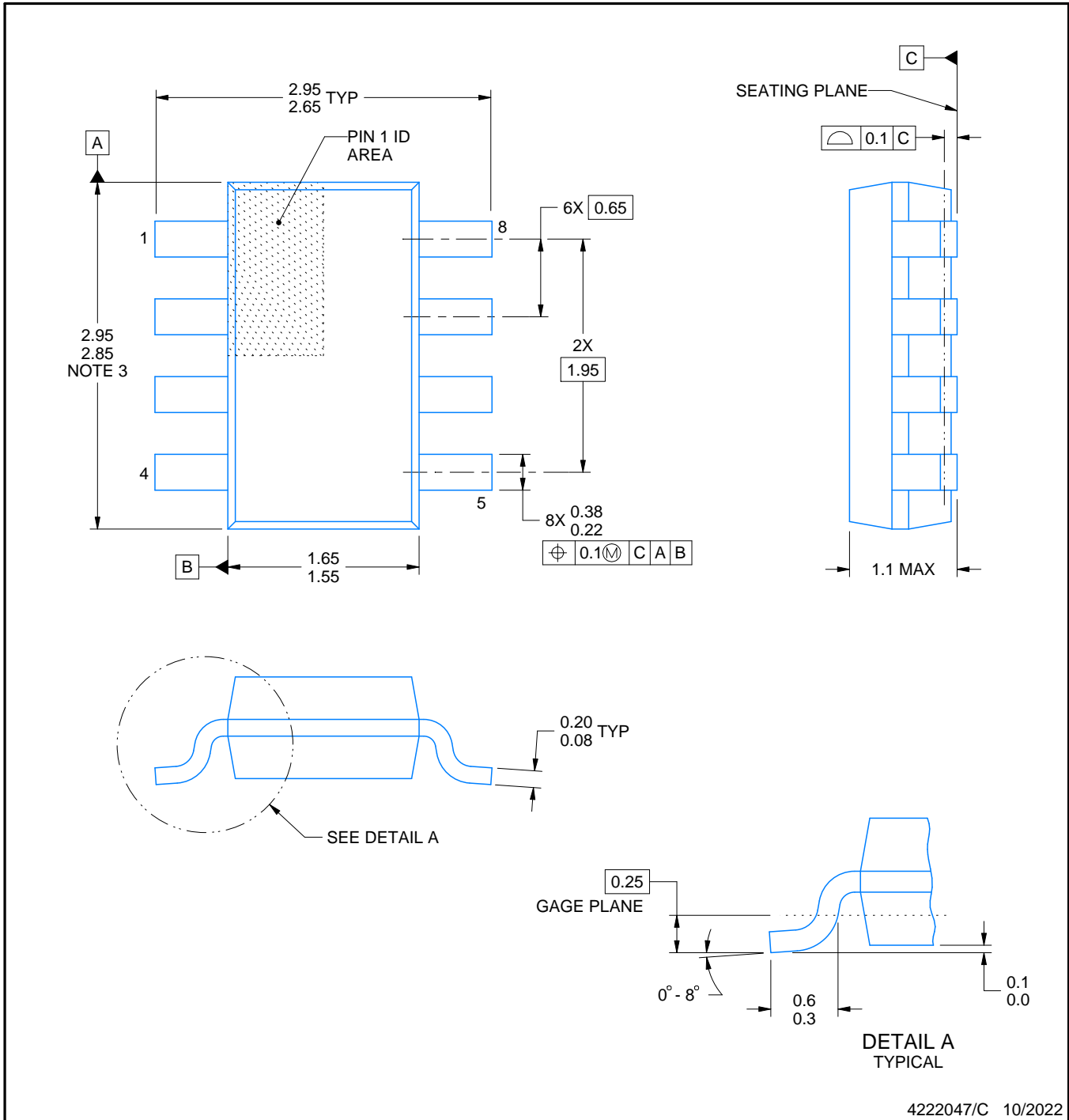
# DDF0008A



# PACKAGE OUTLINE

## SOT-23 - 1.1 mm max height

PLASTIC SMALL OUTLINE



### NOTES:

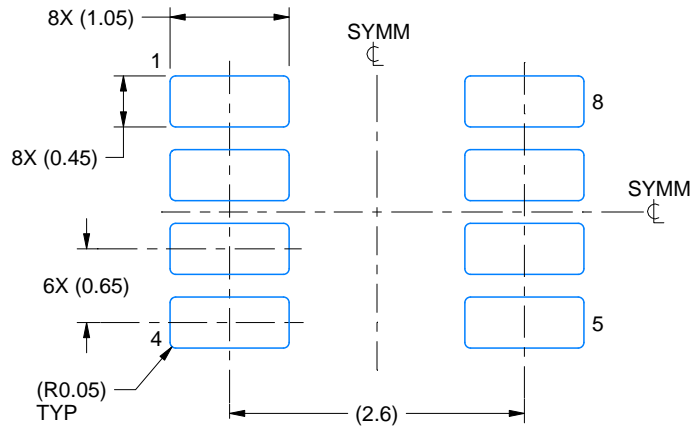
1. All linear dimensions are in millimeters. Any dimensions in parenthesis are for reference only. Dimensioning and tolerancing per ASME Y14.5M.
2. This drawing is subject to change without notice.
3. This dimension does not include mold flash, protrusions, or gate burrs. Mold flash, protrusions, or gate burrs shall not exceed 0.15 mm per side.

# EXAMPLE BOARD LAYOUT

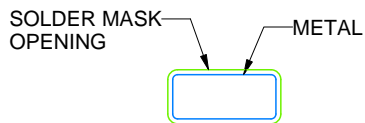
DDF0008A

SOT-23 - 1.1 mm max height

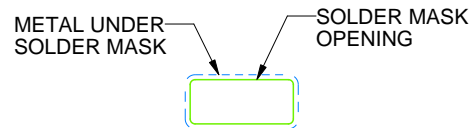
PLASTIC SMALL OUTLINE



LAND PATTERN EXAMPLE  
SCALE:15X



NON SOLDER MASK  
DEFINED



SOLDER MASK  
DEFINED

## SOLDER MASK DETAILS

4222047/C 10/2022

NOTES: (continued)

4. Publication IPC-7351 may have alternate designs.
5. Solder mask tolerances between and around signal pads can vary based on board fabrication site.

# EXAMPLE STENCIL DESIGN

DDF0008A

SOT-23 - 1.1 mm max height

PLASTIC SMALL OUTLINE



SOLDER PASTE EXAMPLE  
BASED ON 0.125 mm THICK STENCIL  
SCALE:15X

4222047/C 10/2022

NOTES: (continued)

6. Laser cutting apertures with trapezoidal walls and rounded corners may offer better paste release. IPC-7525 may have alternate design recommendations.
7. Board assembly site may have different recommendations for stencil design.

## IMPORTANT NOTICE AND DISCLAIMER

TI PROVIDES TECHNICAL AND RELIABILITY DATA (INCLUDING DATA SHEETS), DESIGN RESOURCES (INCLUDING REFERENCE DESIGNS), APPLICATION OR OTHER DESIGN ADVICE, WEB TOOLS, SAFETY INFORMATION, AND OTHER RESOURCES "AS IS" AND WITH ALL FAULTS, AND DISCLAIMS ALL WARRANTIES, EXPRESS AND IMPLIED, INCLUDING WITHOUT LIMITATION ANY IMPLIED WARRANTIES OF MERCHANTABILITY, FITNESS FOR A PARTICULAR PURPOSE OR NON-INFRINGEMENT OF THIRD PARTY INTELLECTUAL PROPERTY RIGHTS.

These resources are intended for skilled developers designing with TI products. You are solely responsible for (1) selecting the appropriate TI products for your application, (2) designing, validating and testing your application, and (3) ensuring your application meets applicable standards, and any other safety, security, regulatory or other requirements.

These resources are subject to change without notice. TI grants you permission to use these resources only for development of an application that uses the TI products described in the resource. Other reproduction and display of these resources is prohibited. No license is granted to any other TI intellectual property right or to any third party intellectual property right. TI disclaims responsibility for, and you will fully indemnify TI and its representatives against, any claims, damages, costs, losses, and liabilities arising out of your use of these resources.

TI's products are provided subject to [TI's Terms of Sale](#) or other applicable terms available either on [ti.com](https://www.ti.com) or provided in conjunction with such TI products. TI's provision of these resources does not expand or otherwise alter TI's applicable warranties or warranty disclaimers for TI products.

TI objects to and rejects any additional or different terms you may have proposed.

Mailing Address: Texas Instruments, Post Office Box 655303, Dallas, Texas 75265  
Copyright © 2023, Texas Instruments Incorporated