

Dec.1.2018 Copyright 2018 HIROSE ELECTRIC CO., LTD. All Rights Reserved.
 In case that the application demands a high level of reliability, such as automotive,
 please contact a company representative for further information.

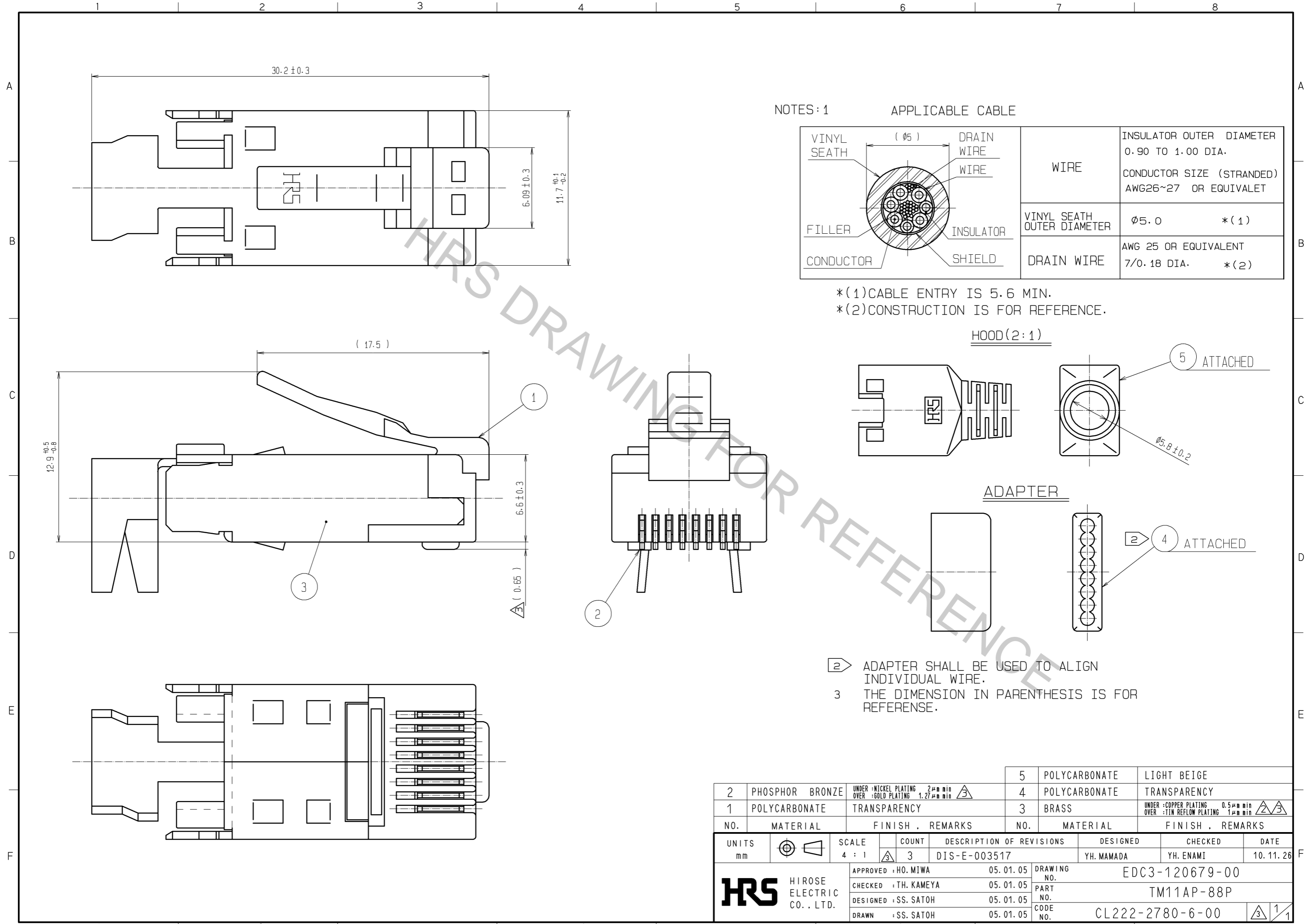

NOTES: 1

APPLICABLE CABLE

VINYL SEATH	(Ø5)	DRAIN WIRE	WIRE	INSULATOR OUTER DIAMETER	0.90 TO 1.00 DIA.
FILLER		WIRE		CONDUCTOR SIZE (STRANDED)	AWG26~27 OR EQUIVALET
CONDUCTOR		INSULATOR	VINYL SEATH OUTER DIAMETER	Ø5.0	*(1)
		SHIELD	DRAIN WIRE	AWG 25 OR EQUIVALENT	7/0.18 DIA. *(2)

*(1)CABLE ENTRY IS 5.6 MIN.
 *(2)CONSTRUCTION IS FOR REFERENCE.

HOOD(2:1)

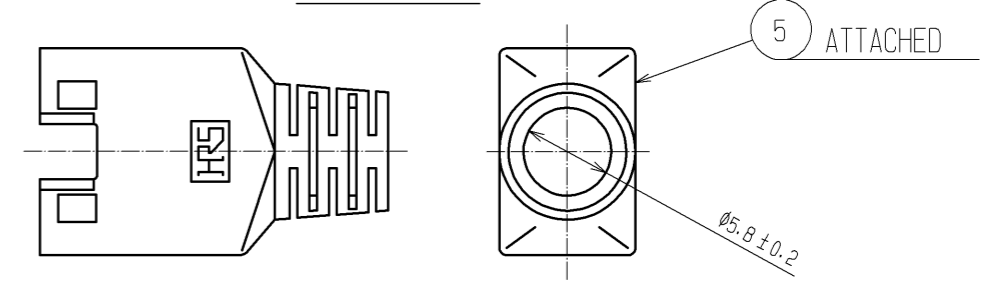

ADAPTER

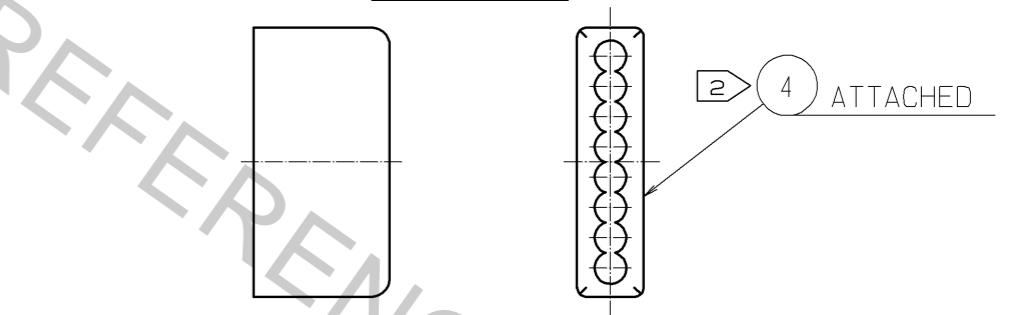

2 ADAPTER SHALL BE USED TO ALIGN INDIVIDUAL WIRE.
 3 THE DIMENSION IN PARENTHESIS IS FOR REFERENCE.

2	PHOSPHOR BRONZE	UNDER :NICKEL PLATING 2µm min OVER :GOLD PLATING 1.27µm min	5	POLYCARBONATE	LIGHT BEIGE
1	POLYCARBONATE	TRANSPARENCY	4	POLYCARBONATE	TRANSPARENCY
			3	BRASS	UNDER :COPPER PLATING 0.5µm min OVER :TIN REFLOW PLATING 1µm min
NO.	MATERIAL	FINISH . REMARKS	NO.	MATERIAL	FINISH . REMARKS
UNITS	mm	SCALE	4 : 1	COUNT	3
		DESCRIPTION OF REVISIONS		DESIGNED	YH.MAMADA
		DIS-E-003517		CHECKED	YH.ENAMI
				DATE	10.11.26
APPROVED : HO.MIWA		05.01.05		DRAWING NO. EDC3-120679-00	
CHECKED : TH.KAMEYA		05.01.05		PART NO. TM11AP-88P	
DESIGNED : SS.SATO		05.01.05		CODE NO. CL222-2780-6-00	
DRAWN : SS.SATO		05.01.05		1/1	